

ISSUE No & DATE	DETAILS OF CHANGE, MODIFICATION RECORD NUMBER, ECR NUMBER.
A 14.2.14	FOR DO REFERENCE ONLY. NOT RELEASED TO PRODUCTION

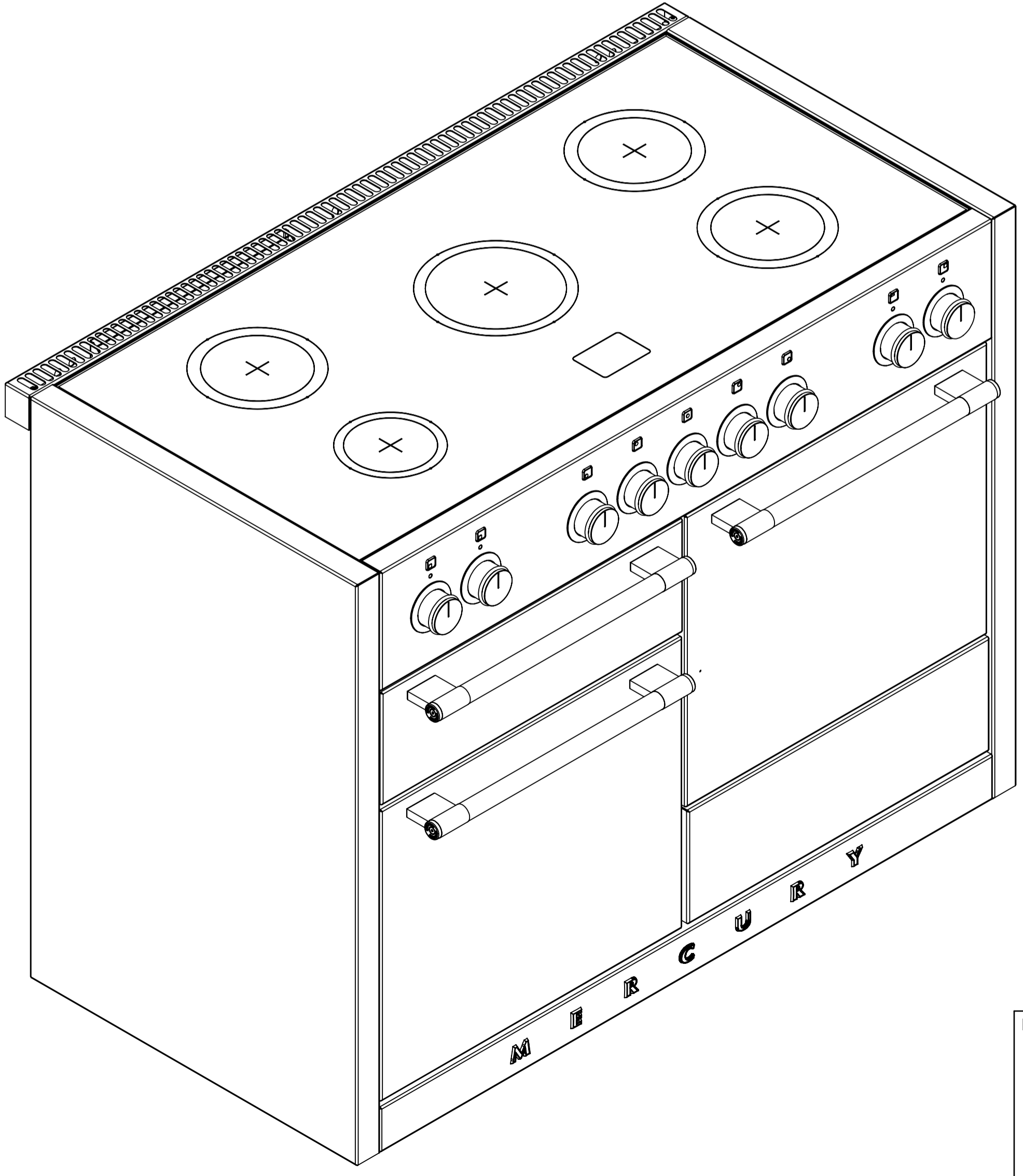
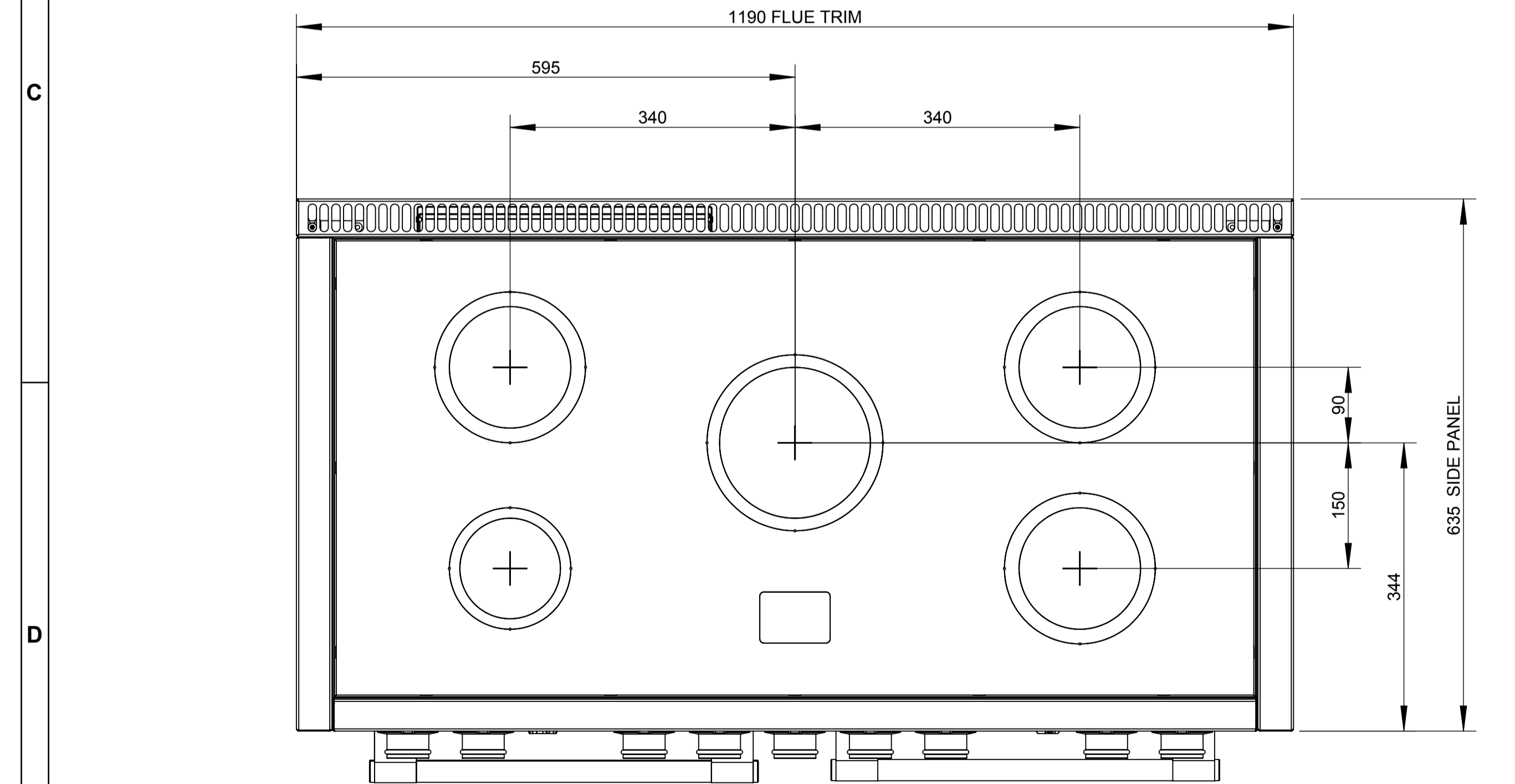

- NOTES:**
1. ALL DIMENSIONS ARE NOMINAL & ROUNDED TO THE NEAREST WHOLE NUMBER, UNLESS SHOWN OTHERWISE.
 2. ALL HEIGHT DIMENSIONS ARE BASED ON THE COOKER BEING SET AT ITS LOWEST LEVEL (IE. *917 DIMENSION), THEY WILL CHANGE ACCORDINGLY WITH THE AMOUNT OF HEIGHT ADJUSTMENT.
 3. FOR DOCUMENTATION PURPOSES THE COOKER IS HEIGHT ADJUSTABLE FROM 920 TO 945
 4. THIS DRAWING IS FOR REFERENCE PURPOSES ONLY. A 'PDF' COPY OF THIS DRAWING FORMS PART OF THE 'APPLIANCE PRODUCT SPECIFICATION' HELD ON THE 'COMMON' DRIVE. CHANGES TO THIS DRAWING REQUIRE THE 'PDF' FILE TO BE UPDATED.

AGA Rangemaster

Clarence Street, Royal Leamington Spa
Warwickshire CV31 2AD, United Kingdom
Telephone: 44 (0)1926 457400
Direct Fax: 44 (0)1926 457611
Web: www.agarangemaster.co.uk

DO NOT SCALE OR GUESS. IF IN DOUBT, ASK. ALL MATERIALS MUST COMPLY WITH RoHS & REACH

ALL MACHINING TO BE FREE FROM BURRS.
TOLERANCES UNLESS OTHERWISE STATED:-
ANGULAR ±30°
WHOLE NUMBERS ±0.5
LINEAR DIMENSIONS ONE DECIMAL PLACE ±0.15
CIRCULAR HOLES ±0.15
CNC BEND RADI 1.25 -0
CNC BEND ANGLES ±2°

PROJECTION

ALL DIMENSIONS IN MILLIMETRES

A1 DRAWING BORDER CREATED 01/08/2012 BY D.J.B

MATERIAL AND FINISH SPECIFICATION

THIS DRAWING IS THE PROPERTY OF RANGEMASTER AND REPRODUCTION IN WHOLE OR PART MAY NOT BE MADE WITHOUT THEIR WRITTEN CONSENT.			
DRAWN	TAB	PROJECT	ASSEMBLY
SCALE	1:5	9576	
TITLE			
MERCURY 1200 INDUCTION STAINLESS STEEL			
PART NUMBER			
A009576			