



AGA 60 Gas Hob

User Guide & Installation Instructions

CAUTION: THIS UNIT IS HEAVY, PROPER EQUIPMENT AND ADEQUATE MANPOWER MUST BE USED IN MOVING THE RANGE TO AVOID DAMAGE TO THE UNIT OR THE FLOOR.

REMEMBER, when replacing a part on this appliance, use only spare parts that you can be assured conform to the safety and performance specification that we require.

DO NOT use reconditioned or copy parts that have not been clearly authorised by AGA.

**PLEASE READ THESE INSTRUCTIONS BEFORE USING THIS APPLIANCE
AND KEEP IN A SAFE PLACE FOR FUTURE REFERENCE.**



For use in AUSTRALIA

08/17 EINS 517558

Make a note of your AGA appliance Serial Number when it is being installed.

The serial number can be found behind the plinth cover.

My AGA Details:

Serial No:

AGA Service No:

Date of Installation:

Contents

1. Health and safety	1	9. Installation Instructions	18
2. Introduction	3	10. Installation introduction	19
3. Overview	4	11. Removal from pallet and appliance installation	20
Control panel	5	12. Specifications	22
Gas hob	5	13. Electrical connection	25
Cooker hoods and oven venting	5	14. Installation sequence and procedure	26
General advice	6	Assembly of burners	26
Using the zones of the AGA 60	6	Fitting of burner cap (<i>rapid and semi-rapid</i>)	26
The ovens	6	Assembly of wok burner (Fig. 14.3)	26
Gas hotplate	7	Gas connection	27
Pan supports	7	Pressure testing	27
Fitting of burner cap (<i>rapid and semi-rapid</i>)	7	Cooker stability	28
Assembly of wok burner (Fig. 3.5)	7	15. Circuit diagram	29
Wok Burner	8	16. Technical data	30
4. AGA Accessories	9	17. Checklist	31
Roasting oven setting	11		
Baking oven setting	11		
Simmering oven	12		
5. Oven shelves	13		
6. Cooking guide	14		
7. Cleaning & caring for your cooker	15		
8. Servicing	17		

1. Health and safety

Consumer protection

As a responsible manufacturer, we take care to make sure that our products are designed and constructed to meet the required safety standards when properly installed and used.

⚠ CHILDREN SHOULD BE KEPT AWAY FROM THE APPLIANCE AS SOME SURFACES CAN BECOME HOT TO THE TOUCH.

The appliance can be used by children aged from 8 years and above and persons with reduced physical, sensory or mental capabilities or lack of experience and knowledge if they have been given supervision or instruction concerning use of the appliance in a safe way and understand the hazards involved. **Children less than 8 years of age shall be kept away unless continuously supervised.** Cleaning and user maintenance shall not be made by children without supervision.

⚠ NEVER store flammable materials in the drawer. This includes paper, plastic and cloth items, such as cookbooks, plastic ware and towels, as well as flammable liquids. Do not store explosives, such as aerosol cans, on or near the appliance.

⚠ DO NOT spray aerosols in the vicinity of the appliance while it is on.

⚠ DO NOT modify this appliance.

⚠ DO NOT use this appliance as a space heater.

⚠ DO NOT use or store flammable materials in or near this appliance.

⚠ DO NOT place articles on or against this appliance.

⚠ NEVER place anything aluminium between the saucepan base and the ceramic surface (i.e. cooking mats, aluminium foil, etc).

⚠ IMPORTANT: Oil is a fire risk, do not leave pans containing oil unattended.

- In the event of a fire cover with a lid and switch OFF the electricity.
- Smother the flames on the hob rather than attempting to remove the pan to the outside.
- Burns and injuries are caused almost invariably by picking up the burning pan to carry outside.

DO NOT hang dish towels on the handrail. Doing so will block the air vent. Blocking the air vent can cause excessive temperature increase to the control panel and prevent easy access.

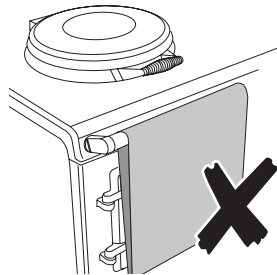

When the oven (s) are on **DO NOT** leave any oven door open for long periods, this will affect the temperature of the oven and may allow controls to become hot.

The appliance may contain some of the materials that are indicated below. It is the Users/Installers responsibility to ensure that the necessary personal protective clothing is worn when handling where applicable, the pertinent parts that contain any of the listed materials that could be interpreted as being injurious to health and safety, see below for information.

Fire cement - when handling use disposable gloves.

Glues and sealants

Exercise caution - if these are still in liquid form use face mask and disposable gloves.

Glass yarn, mineral wool, insulation pads, ceramic fibre

May be harmful if inhaled. May be irritating to skin, eyes, nose and throat. When handling avoid contact with skin or eyes. Use disposable gloves, face-masks and eye protection. After handling wash hands and other exposed parts. When disposing of the product, reduce dust with water spray, ensure that parts are securely wrapped.

⚠ CAUTION: The cooking process has to be supervised. A short term cooking process has to be supervised continuously.

⚠ WARNING!: Unattended cooking on a hob with fat or oil can be dangerous and may result in fire. NEVER try to extinguish a fire with water, but switch off the appliance and then cover flame e.g. with a lid or fire blanket.

⚠ WARNING!: Danger of fire: DO NOT store items on the cooking surfaces.

⚠ WARNING!: Accessible parts may become hot during use. Young children should be kept away.

⚠ During use the appliance becomes hot. Care should be taken to avoid touching heating elements inside the oven.

⚠ DO NOT install the appliance behind a decorative door in order to avoid overheating.

⚠ It is essential that the base or hearth on which both appliance(s) and module stands should be level and capable of supporting the total weight of both units. Refer to the technical data for the weight of each appliance(s).

⚠ It is the customers responsibility to contact a qualified electrical installer to make sure the electrical installation is adequate and in conformance with SAA ELECTRICAL WIRING RULES AS 3000.

⚠ If the supply cord is damaged, it must be replaced by the manufacturer, its service agent or similarly qualified persons in order to avoid a hazard.

⚠ **WARNING!** This appliance must be installed with an appropriate device that will allow permanent disconnection of the Active (Live) and Neutral conductors. During Installation or disconnection prior to any electrical work, the appliance must be permanently disconnected from the Supply Active (Live) and Neutral Conductors.

Deep fat frying

- Use a deep pan, large enough to completely cover the appropriate heating area.

⚠ **NEVER fill the pan more than one-third full of fat or oil.**

⚠ **NEVER leave oil or fat unattended during the heating or cooking period.**

⚠ **NEVER use a lid on the pan.**

⚠ **In the event of a fire, cover the pan with a lid and turn OFF the appliance.**

⚠ **Smother the flames on the hob preferably with a fire blanket, rather than attempting to remove the pan to the outside.**

⚠ **Burns and injuries are caused almost invariably by picking up the burning pan to carry it outside.**

If you smell gas

- **DO NOT** turn electric switches on or off
- **DO NOT** smoke
- **DO NOT** use naked flames
- Turn off the gas at the meter or cylinder
- Open doors and windows to get rid of the gas
- Keep people away from the area affected
- Call your gas supplier.

2. Introduction

As responsible manufacturers we take care to make sure that our products are designed and constructed to meet the required safety standards when properly installed and used.

Your AGA 60 is a compact cooker which combines the design values and cooking principles of the traditional AGA with the flexibility to turn each cooking area off and on as you require, thereby fitting into your lifestyle beautifully.

The AGA 60 has been designed to have all the attributes of a larger AGA within a small space.

Refer to the diagram in the **Overview** chapter to familiarise yourself with the product and refer to the relevant sections for upper oven, lower oven, grill, gas hob etc.

⚠ IMPORTANT NOTICE: PLEASE READ THE ACCOMPANYING WARRANTY.

Any alteration that is not approved by AGA could invalidate the approval of the appliance, operation of the warranty and could affect your statutory rights.

In the interests of safety and effective use, please read the following before using your new AGA appliance.

The use of a gas cooking appliance results in the production of heat and moisture in the room in which it is installed.

Ensure that the kitchen is well ventilated: keep natural ventilation holes open or install a mechanical ventilation device (mechanical extractor hood).

Prolonged intensive use of the appliance may call for additional ventilation, for example, opening of a window, or more effective ventilation, for example increasing the level of mechanical ventilation where present.

Installation must be to local and national wiring regulations and carried out by a qualified engineer.

A little smoke and some odour may be emitted when first switched on. This is normal and harmless (from oven lagging and starch binder on the element insulation) and will cease after a short period of use.

3. Overview

Fig. 3.1

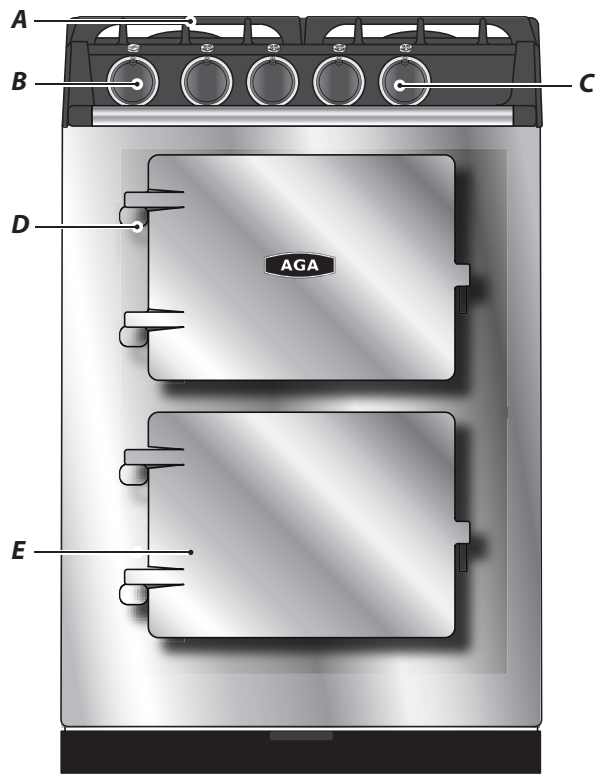

DESN 517561

Fig. 3.2

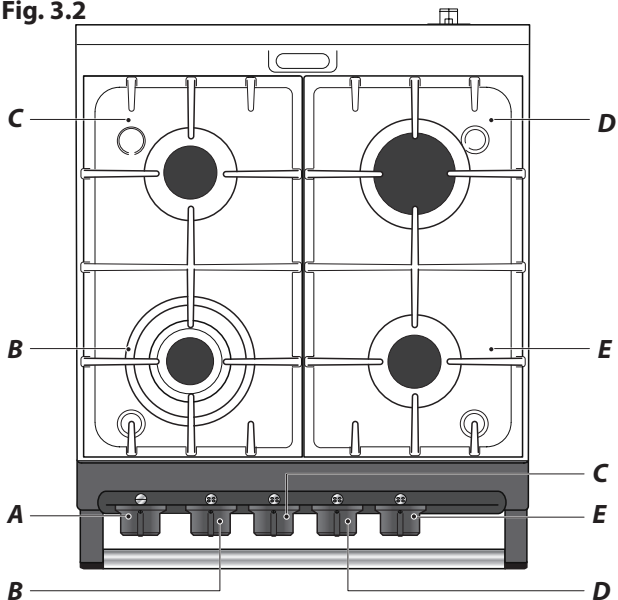

DESN 517562

Cooker overview Fig. 3.1

- A. Gas hob
- B. Oven knob
- C. Gas knobs
- D. Roasting and baking oven
- E. Simmering oven

Gas hob overview Fig. 3.2

- A. Oven knob
- B. Wok burner and knob
- C. Rear semi-rapid burner and knob
- D. Rear rapid burner and knob
- E. Front semi-rapid burner and knob

Control panel

When switching on the AGA cooker for the first few times, there are two things you may notice, neither of which should cause concern.

The AGA cooker will emit an odour for a short while, this is simply due to the protective oil we put on the hotplate and ovens burning off. Due to the newness in the first couple of hours, it is advisable to open the kitchen window while this takes place.

Condensation may occur on the top and front plate whilst the AGA cooker is heating up, caused by the insulation lagging and starch binder on the element insulation drying out. The condensation should be wiped away as soon as possible to prevent staining the enamel.

Your AGA 60 has the external appearance of a classic AGA heat storage enamelled cast iron cooker. However, it's flexibility is almost unbounded because in place of a single heat source each cooking zone has its own electrically heated cast iron element (s). The separation of cooking zones, allows a choice of control. You are able to select only the zones that you want, or need, to use.

PLEASE NOTE: Gas hob and oven controls on this appliance are 'push to turn' operation.

Gas hob

The gas hob control knobs can only be rotated anti-clockwise from the OFF position.

Cooker hoods and oven venting

It is recommended that this AGA is fitted with a cooker hood above it. The AGA venting system is located on top of the AGA and is designed for venting the moisture from the ovens. The cooker hood should be positioned not less than the minimum height as recommended by the manufacturer, from the top of the AGA.









The AGA 60 ovens are manufactured from cast iron, over a period of time they will become individually seasoned.

However, the ovens will rust if high moisture content foods are not covered (especially in the simmering oven) or spillages are not cleaned up.

It is also not advisable to leave a full or partially filled saucepan/utensils with high moisture content food in the ovens when they are not in use.

To season the ovens a light vegetable oil is ideal (corn oil is best), spray oil is recommended. Any stubborn stains can be removed with the wire brush supplied.

Cleaning details can be found on "**Cleaning & caring for your cooker**".

Hobs	
OFF	
Large Flame - High Setting	
Small Flame - Low Setting	
Oven	
OFF	
Top Oven Baking Setting ON Simmering Oven OFF	
Top Oven Baking Setting ON Simmering Oven ON	
Top Oven - OFF Simmering Oven ON	
Top Oven Roasting Setting ON Simmering Oven ON	
Top Oven Roasting Setting ON Simmering Oven OFF	

General advice

Food should not be placed into any oven until it is up to normal operating heat.

The oven doors should not be left open for long periods of time during cooking and heating up.

Store the cold plain shelf outside the cooker. Use it cold in the roasting oven to deflect heat from the top of the oven, creating a more moderate oven temperature underneath. It can also be used as a baking sheet.

Warm up times

As the AGA works on the principle of storing heat, time is required to gather that heat from the electric elements to saturate the castings. **We recommend to allow an hour heat up time.** The optional programmer is a great asset as it can be set to get the top oven to its working heat, ready for you to cook when you walk through the door.

The principle of heat storage means that the ovens and hotplate are at a pre-set heat, the cooking areas are named after their function rather than temperatures.

Using the zones of the AGA 60

The different zones of the AGA 60 cooker are described individually, in the following pages.

The traditional AGA heat storage cooker is famous for the gentle warmth it emits, with the AGA 60 you will get warmth only when the cooker is on or warmth to a lesser degree when only parts of it are on.

The ovens

Your AGA 60 has two ovens which are pre-set at a different heat, just like the traditional AGA heat storage cooker. The top oven has two temperature settings one for the roasting and one for baking.

- The roasting oven setting for high temperature cooking
- The baking oven setting for moderate temperature cooking
- The simmering oven for long, slow cooking.

⚠ DO NOT OPERATE THIS APPLIANCE WITH THE DOORS OPEN, SINCE THIS CAN CAUSE A LOCK-OUT.

Each oven has the same capacity, (able to fit a 13kg (28lb) turkey) and the traditional AGA heat-storage cooker techniques can be used, such as stacking saucepans in the simmering oven. This enables the steaming of root vegetables, rice, steamed pudding, casserole, poaching fruit all in the same oven leaving the hotplate free.

You can have one or two ovens on at their pre-set heat.

The ovens are made from cast iron, which cooks by a radiant heat and this is the secret of the cooking excellence for which the AGA cooker is renowned. An indirect radiant heat does not dry food out, so it retains its natural moisture and flavour.

Gas hotplate

The hotplate has four gas burners: Refer to **Technical Data**.

The semi-rapid burners are especially suited for use with small pans and for gentle simmering or poaching.

All burners have a set simmer position and are easily adjustable.

To use the hotplate burner

To light a hotplate burner push in and turn the control knobs anti-clockwise to the large flame symbol, and hold in for 3 seconds until the burner lights.

Then turn the knob to the required setting.

If the burner flame should accidentally go out, turn off the burner control and do not attempt to re-light the burner for at least one minute.

The control may be set towards a lower position, simply by turning the control knob towards the small flame symbol.

IMPORTANT: The cast iron pan supports on the appliance are much heavier than those on most gas hotplate cookers, therefore care must be taken when removing or re-fitting them to the hob.

It is important that they are lifted from the appliance and not dragged across nearby enamelled parts which would result in damaging the enamel.

Pan supports

It is important for performance and reliability that the pan supports are fitted correctly. They must locate in the recesses in the hob casting (**Fig. 3.3**).

Fitting of burner cap (rapid and semi-rapid)

Place burner cap over retaining lugs, then turn cap clockwise to lock into position (**Fig. 3.4**).

Assembly of wok burner (Fig. 3.5)

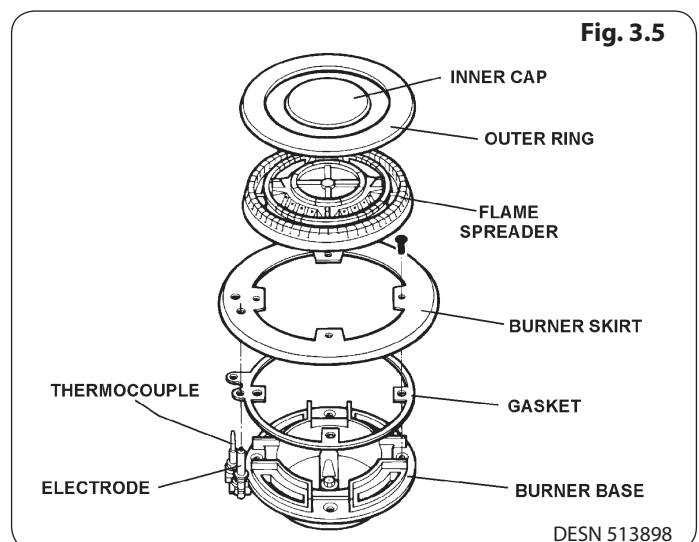
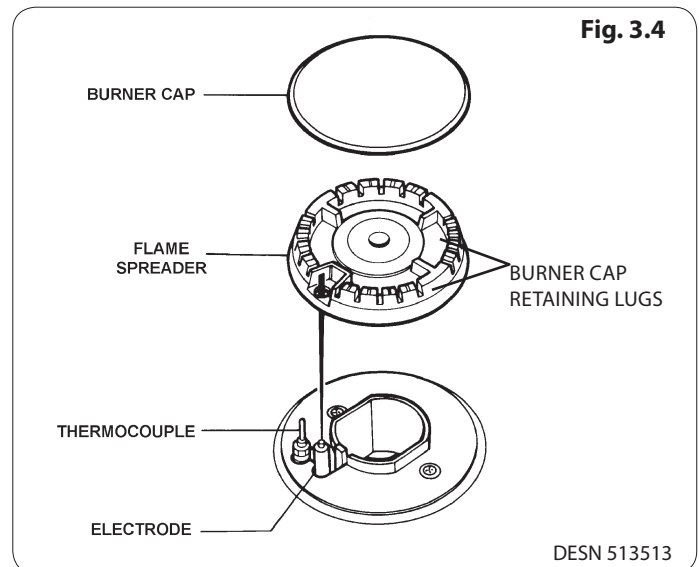
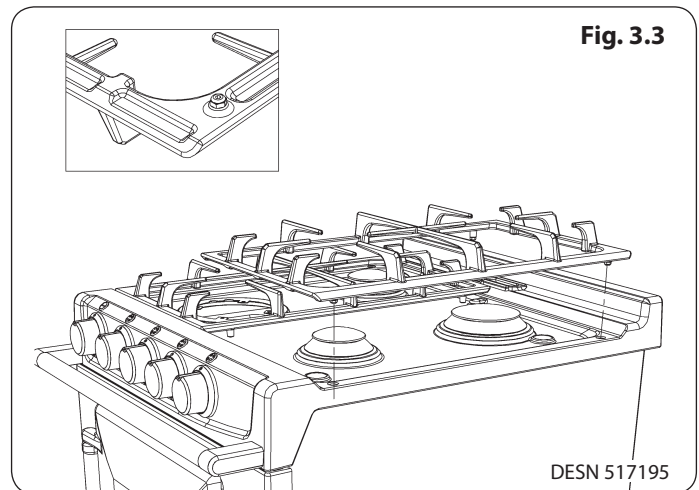

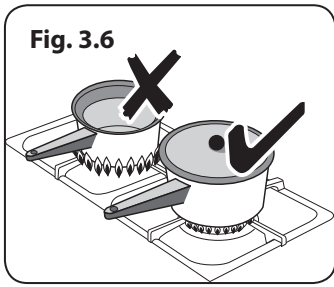

Fig. 3.6

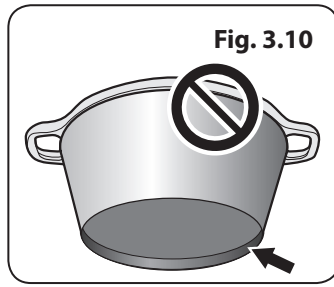

Fig. 3.10

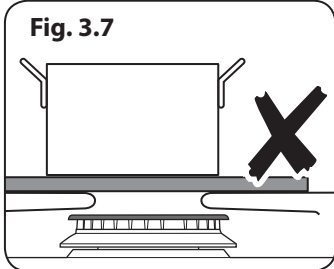

Fig. 3.7

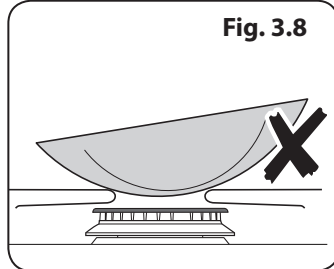

Fig. 3.8

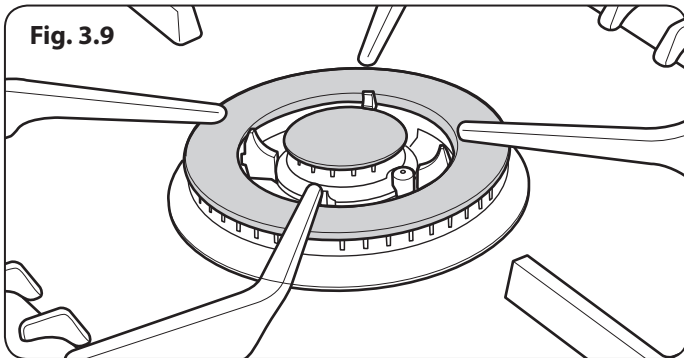

Fig. 3.9

SOME SAFETY POINTS

Make sure that the flames are under the pans. Using a lid will help the contents boil more quickly (**Fig. 3.6**).

Large pans should be spaced well apart.

Pans and kettles with concave bases or down-turned base rims should not be used (**Fig. 3.10**).

Simmering aids, such as asbestos or mesh mats, are **NOT** recommended (**Fig. 3.7**). They will reduce burner performance and could damage the pan supports.

You should also avoid using unstable and misshapen pans that may tilt easily, and pans with a very small base diameter, e.g. milk pans, single egg poachers (**Fig. 3.8**).

The minimum recommended pan diameter is 120 mm. The maximum allowable pan base diameter is 280 mm.

DO NOT use cooking vessels on the hotplate that overlap the edges.

NEVER use pans which overhang the front fascia.

Place all pans centrally over the burners.

Always position pan handles away from the front of the cooker - away from the reach of small children.

NEVER leave a chip pan unattended.

Wok Burner

The wok burner is designed to provide even heat over a large area. It is ideal for large pans and stir-frying (**Fig. 3.9**).

For heating smaller pans, the aforementioned hotplate burners may be more efficient.

You should wipe the enamel top surface of the cooker around the hotplate burners as soon as possible after spills occur. Try to wipe them off while the enamel is still warm.

NOTE: The use of aluminium pans may cause metallic marking of the pan supports. This does not affect the durability of the enamel and may be cleaned off with a suitable metal cleaner.

4. AGA Accessories

To get the very best performance from your cooker we recommend AGA saucepans with the thick tri-core bases and stacking lids so that the maximum use of oven space is made and an AGA kettle for boiling water. AGA Accessories can be viewed at your AGA Specialist or online at www.agacookshop.co.uk

Getting to know your AGA

If you have not already seen a demonstration, ask your AGA Specialist for details. A demonstration will show you how to get the best from your new AGA and will give you hints and tips. You will also see a selection of AGA utensils and accessories being used.

Large Size Roasting Tin with Grill Rack (Fig. 4.1)

This is designed to slide onto the oven runners without the need for it to sit on an oven grid shelf. The roasting tin can be used with the grill rack, in its high position, for grilling at the top of the roasting oven. It can be used for roasting meat, or poultry with or without the grill rack. Large quantities of roast potatoes can be cooked in this tin. The roasting tin can also be employed for making large traybakes or cakes. The grill rack is useful on its own as a cake cooling rack. Can be used in any oven but not recommended for hotplate use.

Half Size Roasting Tin and Grill Rack (Fig. 4.2)

This tin can be slid onto the oven runners width-ways or can sit on an oven grid shelf. The half size roasting tin can be used with the grill rack, in its high position, for grilling at the top of the roasting oven. It can be used for roasting smaller joints of meat, or poultry with or without the grill rack. Roast potatoes can be cooked in this tin. The roasting tin can also be employed for making traybakes or cakes. The grill rack is useful on its own as a cake cooling rack. Can be used in any oven but not recommended for hotplate use.

3 Oven Grid Shelves (Fig. 4.3)

These are for inserting in each oven to provide a surface for dishes and tins which do not fit direct onto the oven runners. They can be used in any oven, as required. See **“Oven shelves” on page 13** on how to locate the oven shelves correctly.

1 Cold Plain Shelf (Fig. 4.4)

This has two uses one as large baking sheet for scones, biscuits, pastry items and meringues and the other use as a heat deflector to cut off the top heat if food is overbrowning before it is cooked through.

⚠ DO NOT STORE IN THE OVENS WHEN NOT IN USE.



Fig. 4.1



Fig. 4.2

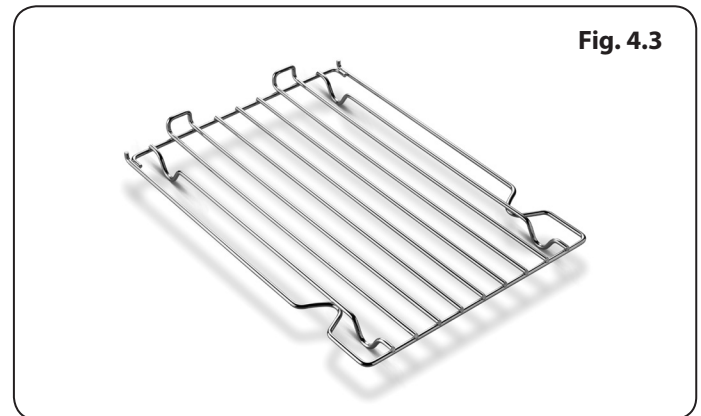
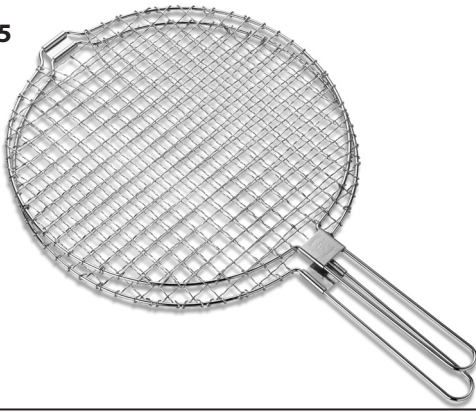

Fig. 4.3



Fig. 4.4

Fig. 4.5



Toaster (Fig. 4.5)

This is for toasting bread on the boiling plate. AGA toast is renowned for its excellence, crisp on the outside and soft in the centre. Take thick slices of bread and place in the AGA toaster - if the bread is very moist or very fresh, heat the toaster beforehand to prevent sticking - lift the boiling plate insulated cover and place the toaster direct onto the plate with the handle at an angle from the handle of the cover.

Close the cover and wait for the bread to toast one side - this will take 1-2 minutes dependent upon the variety of bread - open the cover and turn the toaster over and repeat the process to toast the other side. The toaster can also be used for heating pitta bread, toasting teacakes and as a cake cooling rack.

Fig. 4.6



Wire Brush (Fig. 4.6)

This is for cleaning the raw cast iron surfaces, keeping them clear of crumbs and burnt on debris – which would otherwise affect the boiling performance of pans and the kettle. Use on the hotplates and the ovens. Take care not to touch the enamel surfaces as the wire brush will scratch the finish.

Getting to know your AGA

If you have not already seen a demonstration, ask your AGA Specialist for details. A demonstration will show you how to get the best from your new AGA and will give you hints and tips. You will also see a selection of AGA utensils and accessories being used.

Roasting oven setting

The roasting oven setting is indirectly heated by two elements, one in the base of the oven and the other in the roof. These elements heat the air and the cast iron within to provide cooking results consistent with the traditional AGA heat-storage cooker, with the flexibility of being able to turn the off when not in use.

The roasting oven setting can be used for 'grilling' at the top and 'shallow frying' on the oven floor.

When cooking on the base of the roasting oven, place the floor grid on the base before putting the food into the oven. This lifts the food away from the base element to ensure best cooking results are achieved.

The roasting oven setting is zoned in heat, meaning it is slightly hotter towards the top than the centre and the oven grid shelf set on the oven floor is slightly less hot than the centre.

The base of the oven can be used as another cooking surface, indeed it is often called a hidden hotplate use the floor grid for protection so food does not overbrown.

The beauty of the roasting oven setting is that any fat is burnt off when the oven is at full heat, just brush out occasionally to remove the carbon deposits.

The roasting oven setting is excellent for bread and pastries. Quiches in ceramic or pies in Pyrex dishes need not be baked blind as when they are in placed on the floor grid on the base of the oven the pastry cooks from underneath and the filling will set and brown from the all-round heat. As you are aware metal flat tins conduct heat quicker than ceramic may need less cooking time.

The specially designed roasting tins and bakeware slide directly onto the runners, so almost every available square centimetre of space can be used. Food can be protected by the use of the cold plain shelf or shielded by means of the large roasting tin which means you can cook food that requires different temperatures at the same time. If food is browning too quickly and you do not want to move it to another oven just slide the cold plain shelf over the food to reduce the top heat.

Baking oven setting

The oven is indirectly heated by two elements, one in the base of the oven and the other in the roof. These elements heat the air and the cast iron within to provide cooking results consistent with traditional AGA heat storage cookers, with the flexibility of being able to turn it off when not in use.

This setting is a moderate heat, so is ideal for cakes, biscuits, also anything that requires medium heat cooking such as fish pie, lasagne, soufflés, crumble and roulades. Meat and poultry can be cooked here indeed most things that can be cooked on the roasting oven setting can be cooked on the baking oven setting but for a longer time.

For the best results when cooking cakes do allow at least the one hour heat up time. Cook cakes together on one shelf. If two shelves are used interchange the food to achieve even colouration, as you would with any oven which is zoned heat.

As with the roasting oven setting, the specially designed roasting tins and bakeware slide directly onto the runners, so almost every available square centimetre of space can be used. Food can be protected by the use of the cold plain shelf or shielded by means of the large roasting tin, which means that you can cook food that requires different temperatures at the same time. If food is browning too quickly and you do not want to move it to another oven just slide the cold plain shelf over the food to reduce the heat.

NOTE: When baking it is always best to start from cold, otherwise if baking after using the roasting setting the oven will take a considerable amount of time to cool.

NOTE: Always remove the cold plain shelf and roasting tins on completion of cooking, if left in the oven it will affect the oven temperature.

Simmering oven

The simmering oven is indirectly heated by one element in the base of the oven.

This element heats the air and the cast iron within it to provide cooking results consistent with the traditional simmering oven of the traditional AGA heat-storage cooker, with the flexibility of being able to turn it off when not required.

The floor grid is used here to protect items placed on the base of the oven such as vegetables for steaming, keeping sauces warm or casseroles cooked for a long time. Always ensure this is in place, before putting food into the oven.

The simmering oven can be described as a continuation oven, it continues to cook food that has been brought up to heat elsewhere on the cooker with the exception of meringues which are dried out rather than 'cooked'.

User Guidance

- Allow the oven to heat fully, the longer the oven is on the better, we recommend one hour.
- To get the very best performance, we recommend to use AGA cookware with thick bases and stacking lids.
- **DO NOT** place dishes directly on to the oven base. Always place onto either a shelf or the floor grid.
- Joints of meat and poultry should be brought up to heat ideally on the roasting oven setting for 30-45 minutes, then transferred to the simmering oven.
- This method is unsuitable for stuffed meat and stuffed poultry).
- Make sure that pork and poultry reach an internal temperature of at least 75°C.
- Always bring soups, casseroles and liquids to the boil before putting in the simmering oven.
- Always thaw frozen food completely before cooking.
- Root vegetables will cook better if cut into small pieces.
- Adjust seasoning and thickenings at the end of the cooking time.
- Many dried pulses and beans for example, dried red kidney beans must be boiled for a minimum of 10 minutes, after soaking, and before inclusion in any dish.

5. Oven shelves

Fitting the shelves

Fig. 5.1

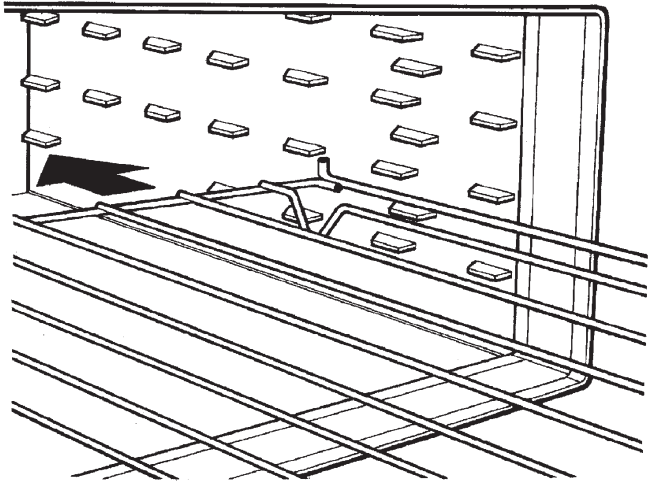

DESN 512403

Fig. 5.2

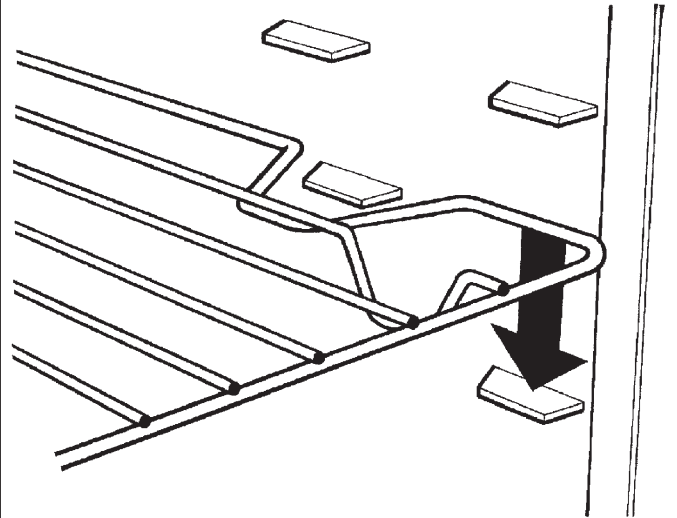

DESN 512404

Removing the shelves

Fig. 5.3

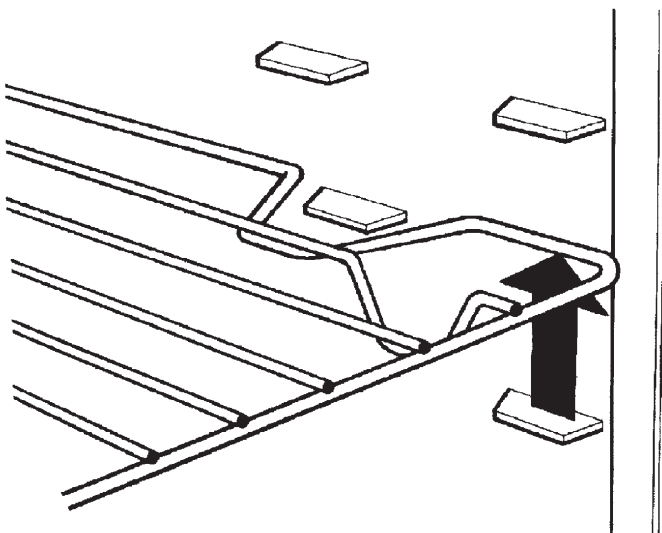

DESN 512405

Fig. 5.4

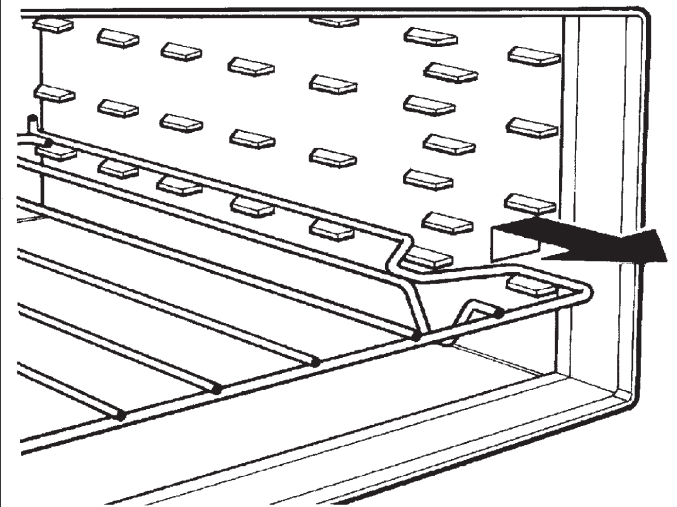

DESN 512406

6. Cooking guide

Roasting oven setting	Oven temperature = HIGH
Grilling	Top - grilling
Scones	2nd runner - scones, small pastries, grilling
Pastries	3rd runner - bread rolls , Yorkshire pudding
Bread	4th runner - roasts, poultry
Yorkshire puddings	Oven grid shelf on base of oven - bread loaves, pies, roast vegetables
Roasts	Floor grid on base of oven - quiches, pies
Shallow frying	
Baking oven setting	Oven temperature = MODERATE
Cakes	Towards top - whisked sponges, some biscuits, small cakes
Biscuits	Middle - fish, soufflés, shepherd and cottage pie, lasagne
Fish Shepherds pie, Cottage pie Lasagne Soufflés Shortbread	Oven grid shelf on base of oven - Victoria sandwiches, shortbread, traybakes and cheesecake
Simmering oven	Oven temperature = LOW
Casseroles Milk puddings Stock Meringues Rich fruit cake	For casseroles, stock, milk puddings and similar dishes bring to heat elsewhere on the AGA then transfer to the simmering oven (one exception is meringues). Rich fruit cakes can be cooked here for a, long time on the oven grid shelf placed on the base of the oven.

WARNING:

Accessible parts may become hot during use. To avoid burns and scalds children should be kept away.

7. Cleaning & caring for your cooker

- ⚠ **REMEMBER: be careful of the hot appliance.**
- ⚠ **For most cleaning it is best when the appliance is turned off.**
- ⚠ **DO NOT use a steam cleaner to clean this cooker.**
- ⚠ **DO NOT use abrasive pads, caustic cleaners, oven cleaners or metal scrapers to clean the surfaces of the enamel.**
- ⚠ **IMPORTANT: AGA recommend Vitreous Enamel Association approved cleaners for cleaning the vitreous enamelled surfaces of this product.**
- ⚠ **When cleaning use as little water as possible.**
- ⚠ **DO NOT immerse the doors in water as they are packed with insulating material, which will be damaged by excessive moisture.**
- ⚠ **DO NOT put oven doors or resting plates in a dishwasher.**

Enamelled roasting tins

- ⚠ **Supplied with the appliance should be cleaned in hot soapy water, soaking if necessary. A nylon scouring pad can also be used. They may also be cleaned in the dishwasher, but with constant use, the enamelled finish will become dull in appearance.**

Enamelled cast iron

- ⚠ **The easiest way to clean the AGA top plate and front plate is to mop up spills as they happen. VEA approved AGA Enamel Cleaner can be purchased from www.agacookshop.co.uk.**
- ⚠ **Baked on food is more difficult to clean but can usually be removed with proprietary vitreous enamel cleaners or mild cream cleaners using a cloth, or if necessary, a nylon scouring pad and can be purchased from www.agacookshop.co.uk.**
- ⚠ **If milk or fruit juice, or anything containing acid is spilt on the enamel, wipe off immediately.**
- ⚠ **Clean off any condensation streaks on the front plate around the oven doors or vitreous enamel maybe permanently discoloured.**
- ⚠ **All that is usually needed to keep the vitreous enamelled surfaces of your cooker bright and clean is a daily rub over with a damp, soapy cloth followed immediately with a clean, dry cloth to avoid streaks.**
- ⚠ **Remember the top plate and the polished covers will scratch if pans or utensils are dragged across them.**

To keep the vitreous enamel surfaces of the cooker bright and clean, a daily rub over with a damp soapy cloth followed immediately with a clean, dry cloth to avoid streaks is all that is required. AGA E-cloths are excellent for this.

Cast iron ovens and hotplates

Ovens - are made from cast iron and keep themselves clean. They are very durable, but will rust if surface moisture is left on them. Remember to always switch the ovens on, to dry them out after cleaning.

Heating up the ovens periodically will help burn off any cooking deposits to aid cleaning within the ovens.

To season the ovens, a light vegetable spray oil (corn oil is best) is recommended. Any stubborn stains can be removed with the wire brush supplied.

Gas Hob - If spillage does occur on a burner cap or pan support, move pan to another burner and when cool, clean in hot soapy water.

After cleaning, be sure all parts are dry. When fitting the burner cap and burner head, make sure that the hole in the burner head is correctly located over the ignition electrode (See "**Gas hotplate**"), and that the burner cap is sitting correctly on the flame spreader.

The ignition electrode must not be displaced or damaged otherwise spark ignition will be affected.

The gas hob is sealed. To clean, remove pan supports and wipe over visible surface.

Hotplates - is made from cast iron, and is easy to care for. Regular maintenance will ensure long-life. They will rust if surface moisture is left on them

Should the hotplates become soiled, use a sponge, cloth, scouring pad or wire brush to remove burnt-on spills.

Rinse off detergents or cleaning agents thoroughly.

Remember to switch on the hotplate for a few minutes to dry it after cleaning. Every now and then, apply a thin coating of vegetable oil (corn oil is best) when the hotplate is cold.

Lids and oven door/lids linings

The top of the insulated cover (lid) - this is chrome or stainless steel and can be kept clean by wiping over with a damp cloth and polished up - the AGA E-cloths are excellent for this purpose as they are lint-free and eco-friendly. AGA stainless steel and chrome cleaner are recommended to keep the insulated cover clean and shining. These can be purchased from your local AGA Specialist.

Lining of the insulated cover (lid interior) - the use of an AGA splash shield is recommended to keep the lining free of fat splashes, (obtainable from your AGA Specialist or on-line at www.agacookshop.co.uk).

WARNING:

Accessible parts may become hot during use. To avoid burns and scalds children should be kept away.

If the lining is marked it is best cleaned when the hotplate is cold. It can be cleaned with hot soapy water and/or a cream cleanser. If badly marked then a soap impregnated pad can be used - this should be used in a circular motion.

The first few times a soap impregnated pad is used you will see the circular marks, these will become reduced and the surface of the lining becomes shinier each time when used. Do not use excessive water and make sure the lining is dry before closing the cover.

Oven door linings - the linings can be cleaned with hot soapy water, a cream cleanser or soap impregnated pad. To deep clean the lining place a towel on the work surface and carefully lift off the oven door (doors are heavy) and place it enamel side down on the towel padding. Clean with a soap impregnated pad to remove stubborn marks. Dry off before replacing on their hinges.

8. Servicing

- To keep your Aga appliance running efficiently we recommend that it is regularly serviced by an Approved Aga engineer. Approved Aga engineers have been factory trained and always use genuine Aga spares
- In the event of requiring maintenance, please call AGA Service or your authorised distributor.
- Your appliance **MUST** only be serviced by a qualified engineer from AGA or an authorised distributor.
- **DO NOT** alter or modify the appliance.

 **A hot appliance cannot be serviced.**

Service intervals to maintain the appliance warranty are as follows:

- An interim service is due at 2 ½ years (30 months) to check and change consumable items, and to undertake a safety check.
- A full service is due at the end of year 5 (60 months). The appliance does not cover Commercial use (see separate warranty book provided for further details).

Spare Parts

To maintain optimum and safe performance, we recommend that only genuine AGA spare parts are used. These are available from most major spares stockists, including ourselves.

9. Installation Instructions

WARNING!

Please read the Warning, Cautionary notes at the start of this section. If the information contained within these instructions is not followed, property damage or personal injury may occur.

DO NOT store or use gasoline or other flammable vapors and liquids in the vicinity of this or any other appliance.

WHAT TO DO IF YOU SMELL GAS

DO NOT try to light any appliance.

DO NOT touch any electrical switch.

DO NOT use any phone in your building.

**Immediately call your gas supplier from a neighbor's phone.
Follow the gas supplier's instructions.**

If you cannot reach your gas supplier, call the fire department.

Installation and service must be performed by a qualified installer, service agency or the gas supplier.

WARNING! This appliance must be installed with an appropriate device that will allow permanent disconnection of the Active (Live) and Neutral conductors. During Installation or disconnection prior to any electrical work, the appliance must be permanently disconnected from the Supply Active (Live) and Neutral Conductors.

CAUTION: THIS UNIT IS HEAVY, PROPER EQUIPMENT AND ADEQUATE MANPOWER MUST BE USED IN MOVING THE RANGE TO AVOID DAMAGE TO THE UNIT OR THE FLOOR.

REMEMBER, when replacing a part on this appliance, use only spare parts that you can be assured conform to the safety and performance specification that we require.

DO NOT use reconditioned or copy parts that have not been clearly authorised by AGA.

**PLEASE READ THESE INSTRUCTIONS BEFORE USING THIS APPLIANCE
AND KEEP IN A SAFE PLACE FOR FUTURE REFERENCE.**

10. Installation introduction

Consumer protection

As a responsible manufacturer, we take care to make sure that our products are designed and constructed to meet the required safety standards when properly installed and used.

CAUTION: THIS INSTALLATION MUST MEET THE REQUIREMENTS OF AS/NZS 5601, AND MUST CONFORM WITH LOCAL GAS AUTHORITIES AND SAA ELECTRICAL WIRING RULES AS 3000 AND ONLY USED IN A WELL VENTILATED SPACE, READ THESE INSTRUCTIONS BEFORE INSTALLING OR USING THIS APPLIANCE.

PRIOR TO INSTALLATION, ENSURE THAT THE LOCAL DISTRIBUTION CONDITIONS (NATURE OF GAS AND GAS PRESSURE) AND THE ADJUSTMENTS OF THE APPLIANCE ARE COMPATIBLE.

THE GAS ADJUSTMENT CONDITIONS FOR THIS APPLIANCE ARE STATED ON THE DATA PLATE WHICH ON A PULL-OUT PLATE BEHIND THE PLINTH COVER.

Refer to the **“Checks for the installer” on page 19** to test the operation of appliance.

This appliance is not connected to a combustion products evacuation device. It shall be installed and connected in accordance with current installation regulations. Particular attention shall be given to the relevant requirements regarding ventilation.

It should be in accordance also with any relevant requirements of the Gas Region and Local Authority.

On completion test the gas installation for soundness and purge. Leak testing of the appliance shall be conducted according to the manufacturer’s instructions.

NOTE: Use soapy water solution on new gas connections to ensure there are no gas leaks.

WARNING - ELECTRIC SHOCK HAZARD

It is the customers responsibility to contact a qualified electrical installer to make sure the electrical installation is adequate and in conformance with SAA ELECTRICAL WIRING RULES AS 3000.

Take special care when cutting holes in walls or floor. Electrical wires may be behind the wall or floor covering and could cause an electrical shock if you touch them.

Locate any electrical circuits that could be affected by the installation of this product and disconnect power circuit.

Electrical earth is required on this appliance.

DO NOT use an extension lead with this appliance.

Checks for the installer

Check with a qualified electrician if you are not sure the appliance is properly earthed.

Failure to follow these instructions could result in death or serious injury.

Check the operation of the appliance to ensure the hotplate burners ignition operates correctly on individual burners and in combination with other burners. Check flame picture and flame stability.

Check oven elements heat up and that ovens reach temperature.

WARNING: THIS APPLIANCE MUST BE EARTHED.

- The appliance is designed for the voltage stated on the data plate.

11. Removal from pallet and appliance installation

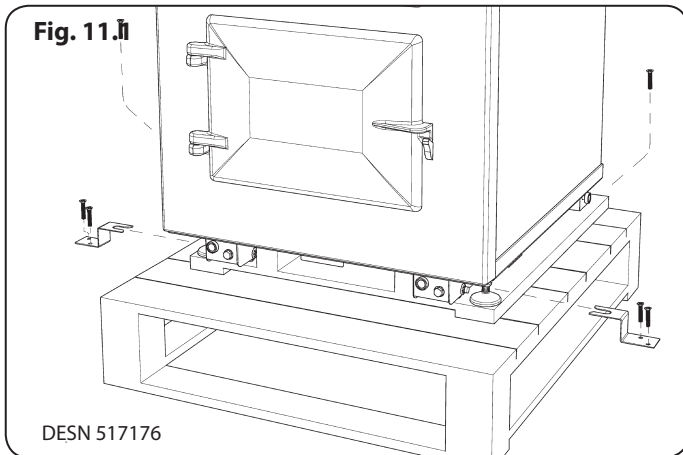

1. Removing of transit brackets - Unscrew 4 screws and remove brackets, from front and two screws from rear (**Fig. 11.1**).
2. **NOTE:** Care must be taken not to trap mains cable. Appliance to be removed from rear of pallet only. Recess provided for suitable sack truck. Appliance to be secured to sack truck with suitable straps (shaded area) (**Fig. 11.2**).
3. Once appliance is in position in kitchen, remove sack truck and straps. The front stability feet can be raised with a spanner to allow appliance to be slid from transit pallet (**Fig. 11.3**).
4. Slide cooker off transit pallet. Take care not to trap mains cable (**Fig. 11.4**).

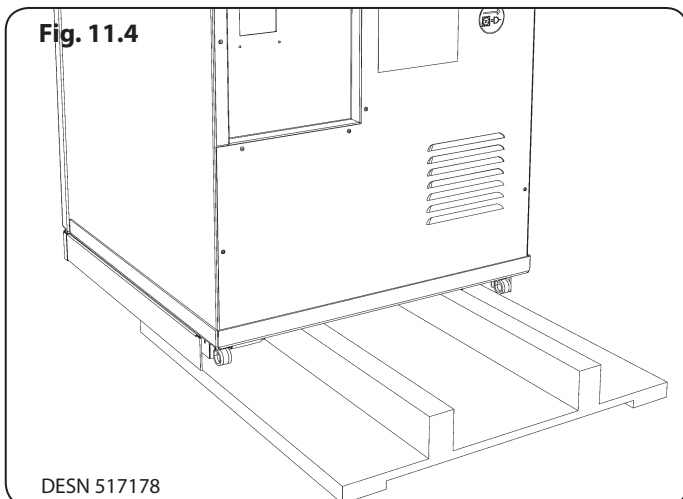
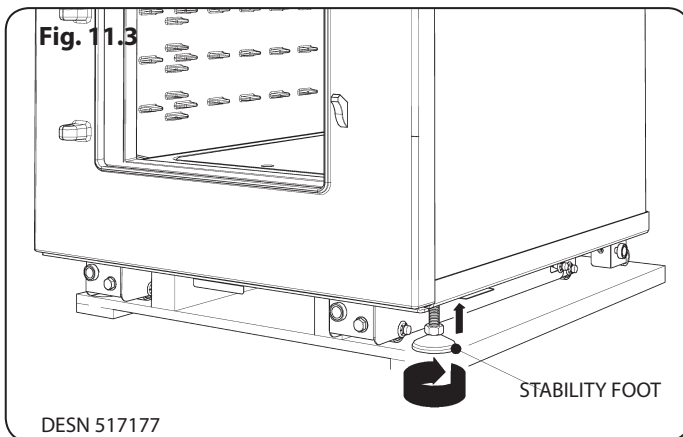
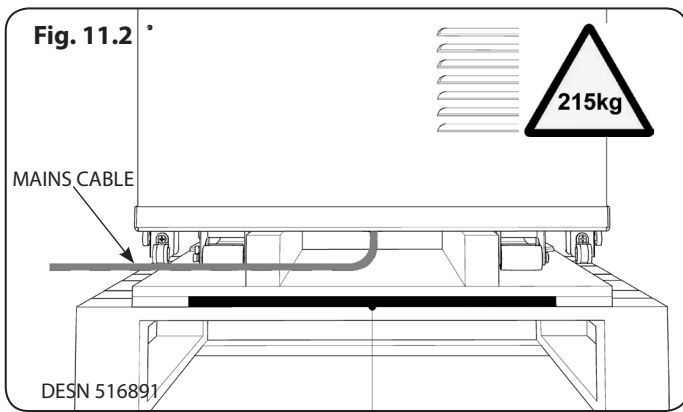

5. Appliance can now be pushed back on its wheels into desired position. **NOTE:** Care must be taken not to trap mains cable (**Fig. 11.5**).
6. **Levelling of appliance** - Use 13mm socket to adjust wheel mechanism for FINE adjustment on both sides at rear of the appliance (**Fig. 11.6**).
7. Using a 12mm open end spanner, feet can be adjusted at front to make FINE adjustments to the front of the appliance and to provide a brake for the wheels (**Fig. 11.6**).
8. Turning the bolt clockwise will lower the wheel thus increasing height of the cooker (**Fig. 11.6**).
9. Anti-clockwise lifts the wheels and lowers the cooker (**Fig. 11.6**).
10. Fit the magnetic plinth (**Fig. 11.7**)

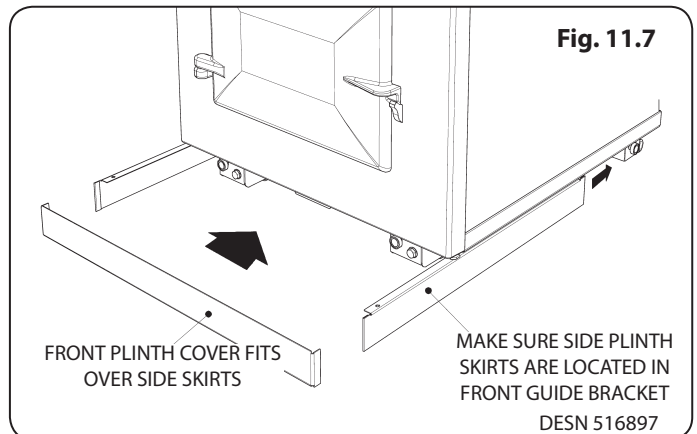
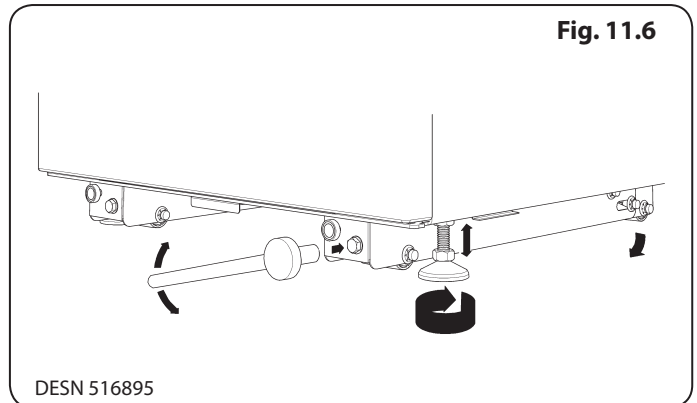
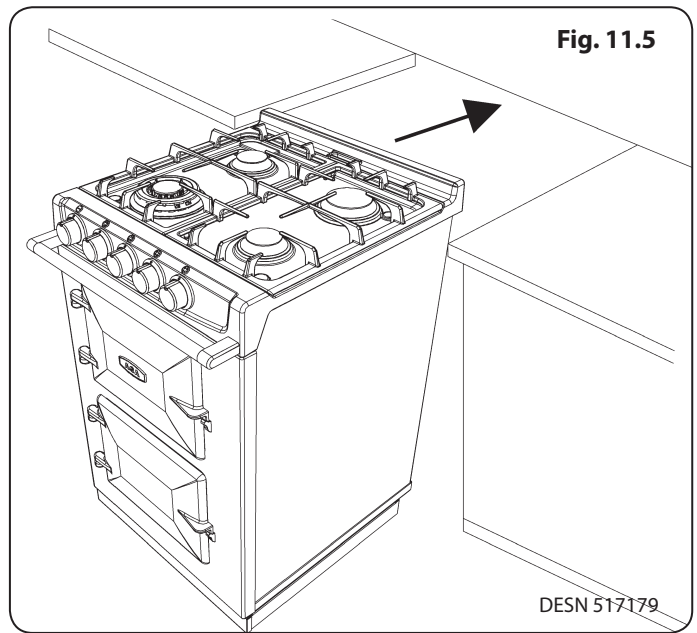

12. Specifications

Fig. 12.1

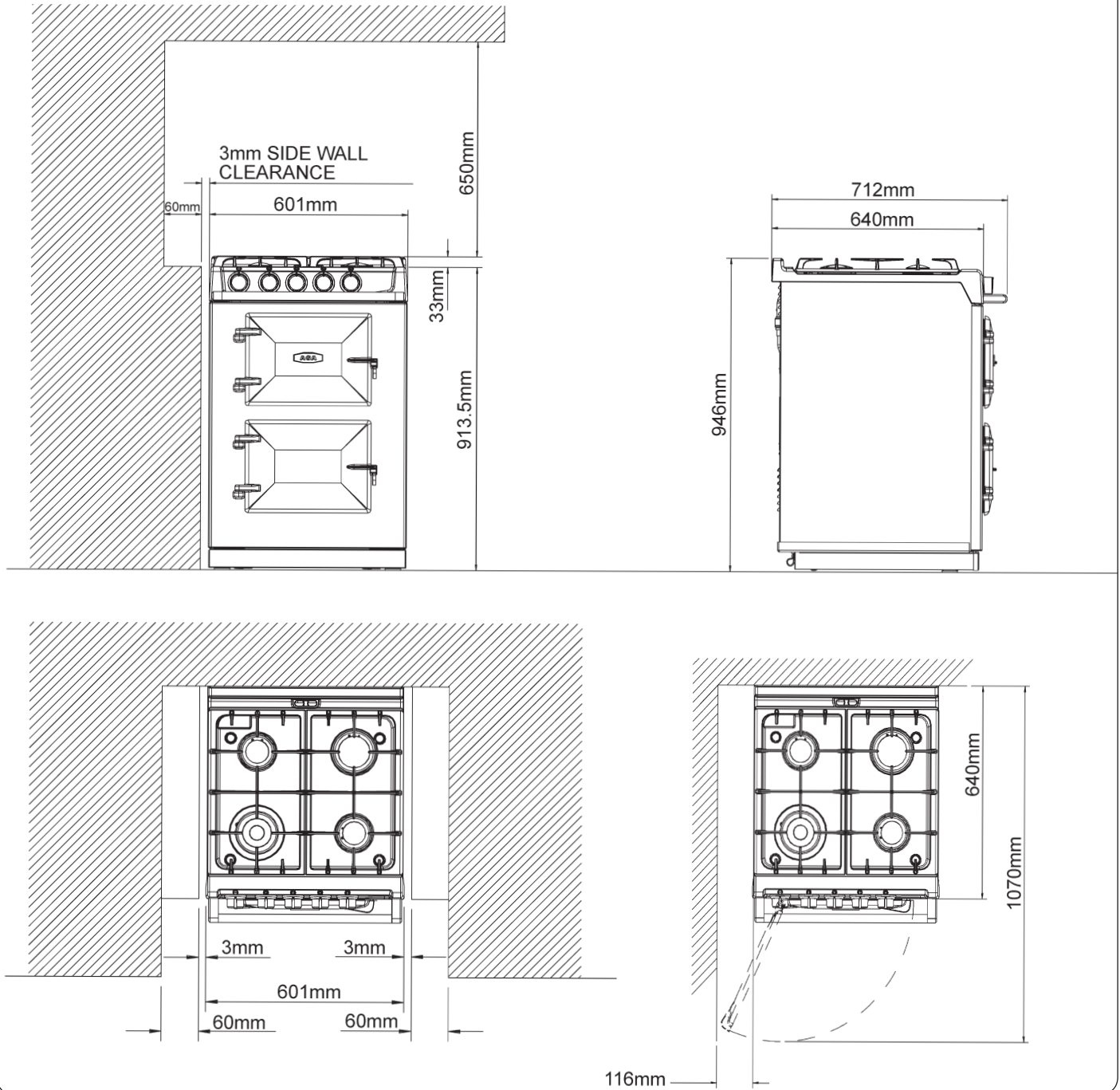

Clearances for overhead cupboards - Fig. 12.1.

NOTE: When surveying for a appliance installation the actual clearance required for the 'body' of the appliance should be increased overall by 10 mm ($\frac{3}{8}$) beyond the figures quote above. This allows safe margin to take into account the natural dimensional variations found in major castings in particular the width across an appliance recess could be critical.

Appliance weight (Excludes packaging)

Model: AGA 60 Gas Hob 474 lbs (215 kg)

Side Clearances

If you are installing the appliance in a new kitchen or have the opportunity to set the width between kitchen units, it is advisable to include an additional small gap each side of 3mm to assist with installation and prevent damage when moving the product.

A 6mm additional width clearance should also be provided if the appliance is to go into a brick recess, to allow for the wall being out of square.

Where it is installed against a side wall protruding in the front of the appliance a 116mm clearance is required on the left hand side for the oven door access.

Any side wall above the appliance on either side shall not be less than 60mm horizontally from the appliance (**Fig. 12.1**).

Surfaces over the top of the appliance must not be closer than 650mm.

The vent slot in the back of the top plate must not be obstructed.

Fitting into a 60cm gap

If you are restricted to a 60cm width space, the AGA 60 will fit, subject to the following guide (**Fig. 12.2**).

The appliance top plate casting width tapers outwards at its bottom edge. Consequently adjacent cupboard units should have a maximum depth of 595mm (including doors). If they are deeper, bring the appliance forward.

The thickness of adjacent worktops should not exceed 45mm.

Appliance Base or Hearth

It is essential that the base or hearth on which the appliance stands should be level and be capable of supporting the total weight of the appliance.

The front plinth cover is removable and must not be obstructed by flooring or tiles. If necessary the appliance must be raised by the thickness of the tiles to ensure the plinth can be removed, and the appliance can be rolled out for service.

Tiling

When the appliance is to stand in a recess or against a wall which is to be tiled, in no circumstances should the tiles overlap the appliance top plate, access to remove the top plate must be allowed for servicing at a later date.

Option Pre-heat Timer Kit (AE4M231659)

If the optional pre-heat timer kit is fitted allowances must be made for timer location and the cable between the timer and appliance. Timer cable is 4 metres.

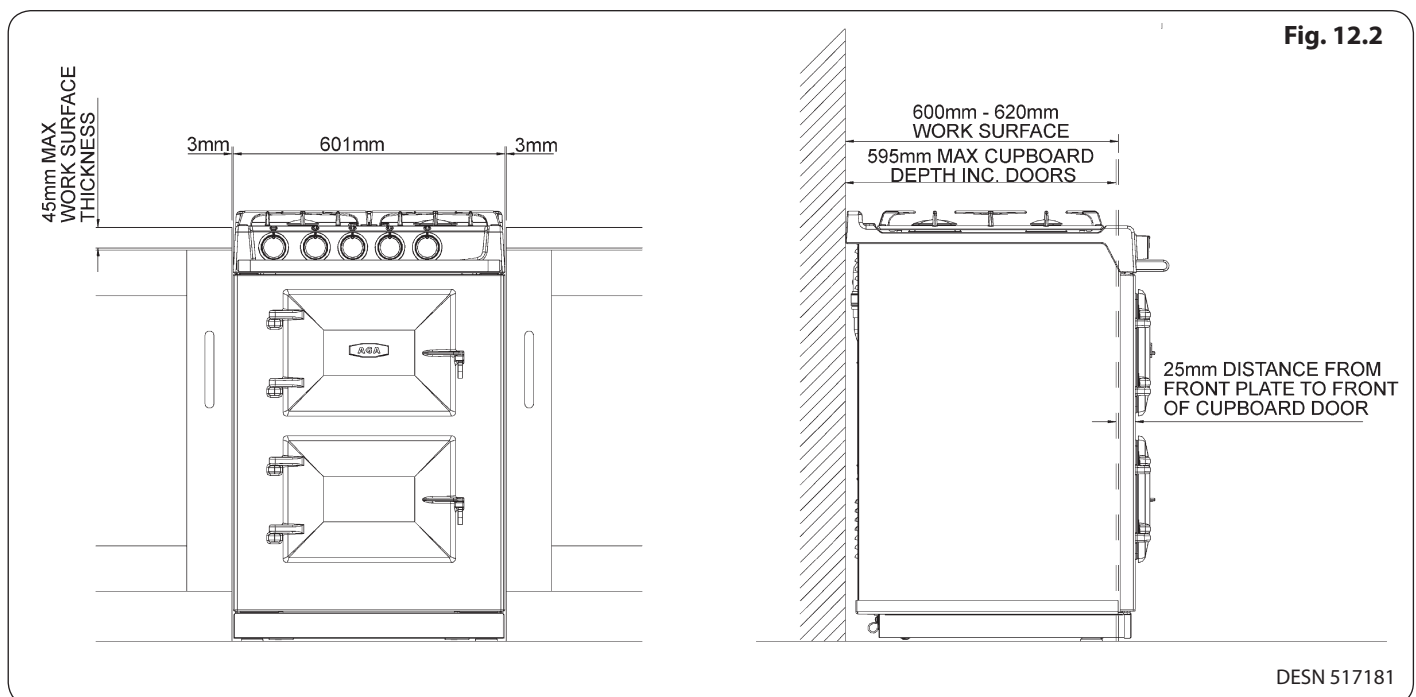
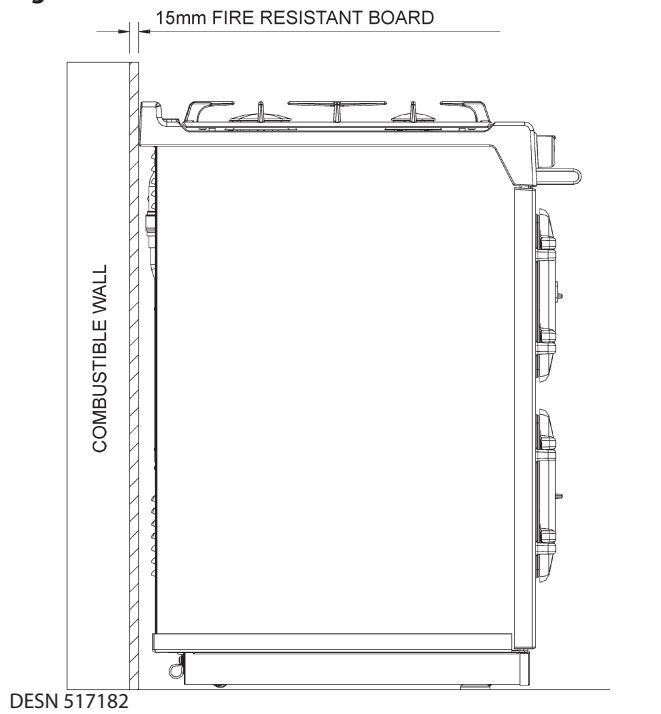

Fig. 12.3 COMBUSTIBLE WALL FITTING USING FIRE RESISTANT BOARD



Combustible Rear Walls

Since this appliance can be used continuously, please take note of the **IMPORTANT INSTRUCTIONS**.

Where the rear wall is constructed of combustible materials (such as all-timber or stud wall partitions and batoned plasterboard) these will require special wall heat protection measures.

Non-combustible insulation board as a protective cladding can be used behind the appliance of at least 15mm thick, such as Monolux or equivalent. This should be taken up to hotplate level (**Fig. 12.3**).

The 5mm air gap must be left open and **NOT** blocked off across the top edge (**Fig. 12.4**).

SPECIAL NOTE: Ensure that unprotected electric cabling or plastic services do not pass within or on the outside of the wall behind or directly above the appliance. This type of material can age prematurely when exposed to continuous higher temperature.

Other Clearances

A minimum clearance of 1000mm must be available at the front of the appliance to enable it to be serviced.

Fig. 12.4 COMBUSTIBLE WALL FITTING CLEARANCE

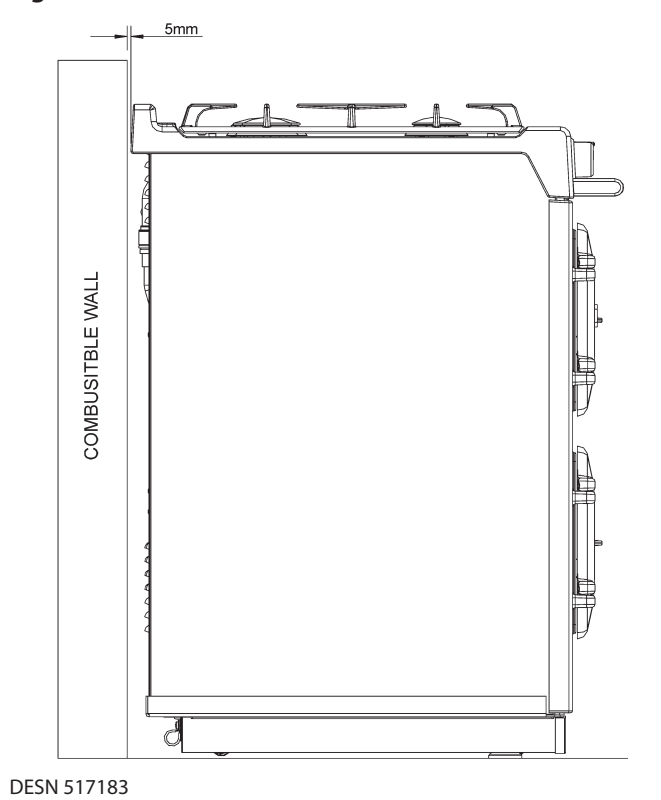

13. Electrical connection

⚠ WARNING: THIS APPLIANCE MUST BE EARTHED. THIS APPLIANCE IS DESIGNED FOR THE VOLTAGE STATED ON THE RATING PLATE, WHICH IS SITUATED BEHIND THE PLINTH COVER.

A 1PH 32 amp 240V or 3PH 400V minimum 16A per phase ~ 50 Hz fused electrical supply is required adjacent to the appliance. External wiring to the unit must be installed using the mains cable provided, in accordance with the current wiring regulations and any local regulations which apply. If cable is shortened, new ferrules must be fitted to the stripped conductors.

The method of connection to the mains electricity supply must facilitate complete electrical isolation of the appliance, by a multi-pole switch, having a contact separation of at least 3mm on all poles.

The isolator should not be positioned immediately above the appliance, but must be fitted within 2 metres of the appliance.

The isolator may be separate from the connection point.

The mains connection point must be accessible within the areas (Fig. 13.2) for cable routing options.

A fully recessed cooker connection box may be located immediately behind the appliance (in the hatched area only Fig. 13.2) . A gap of 5mm must be allowed at the rear of the cooker.

For 2 or 3 phase installations an optional adaptor kit must be obtained (Part No. AE4M280352).

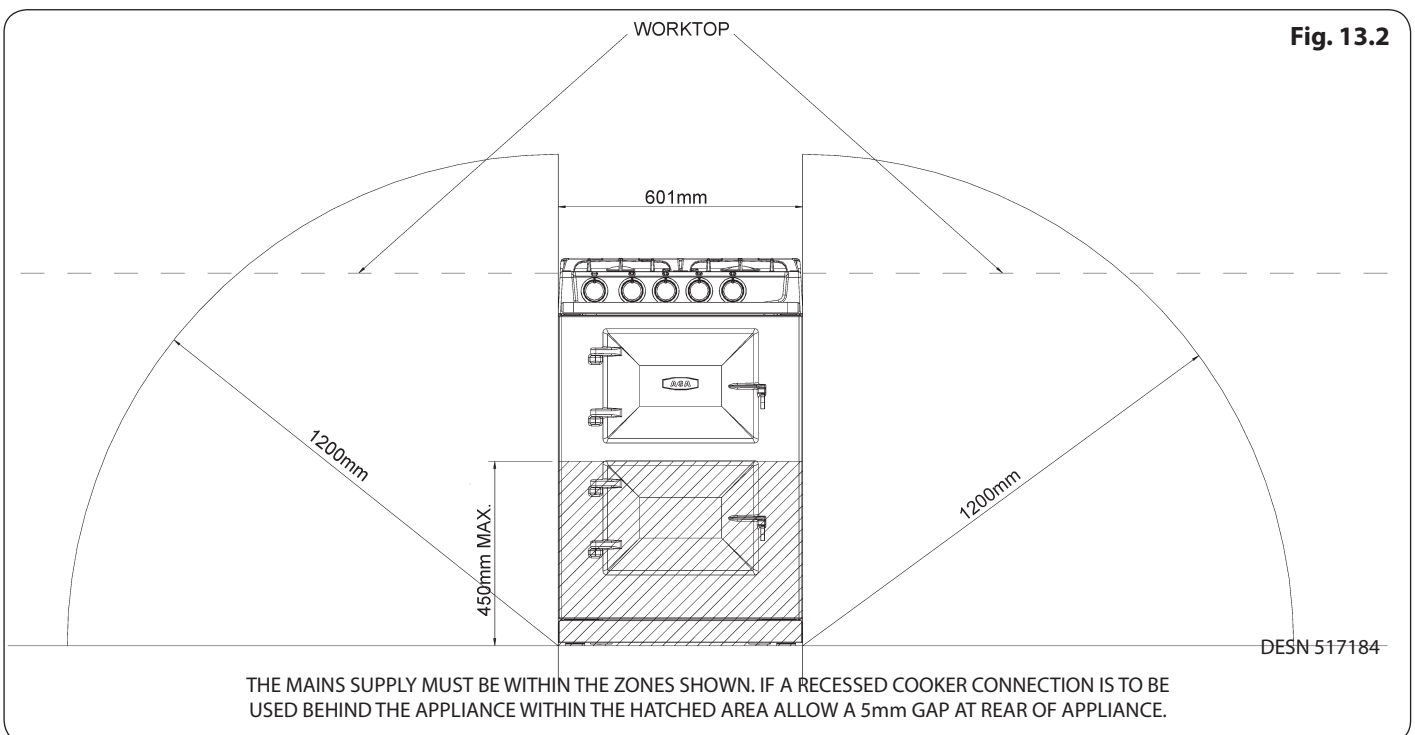
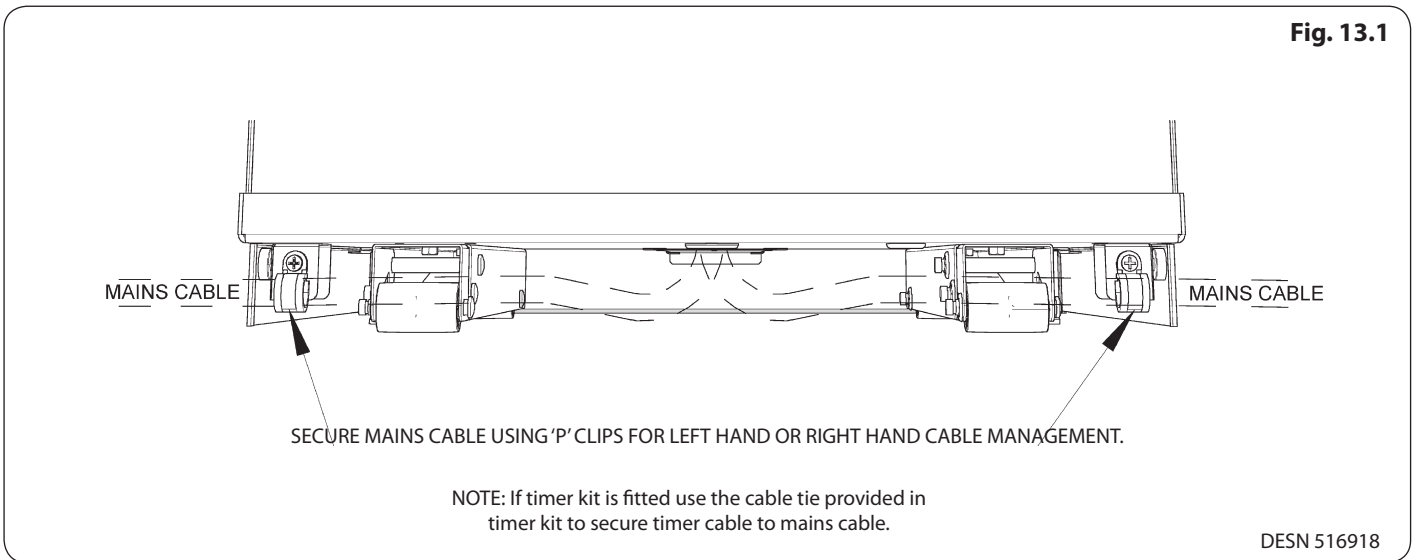

14. Installation sequence and procedure

Fig. 14.1

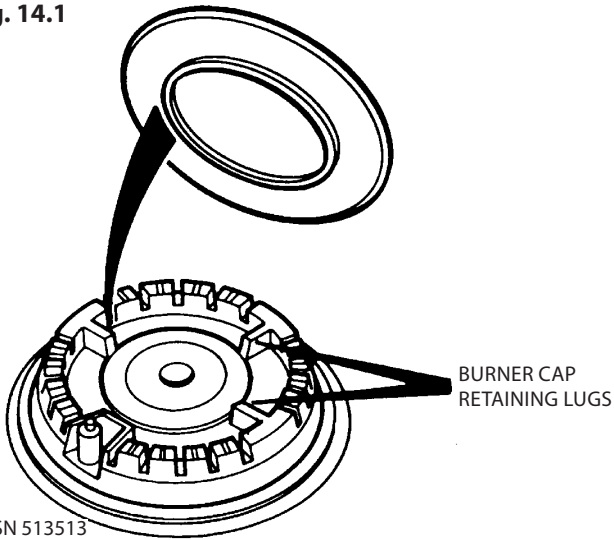

Assembly of burners

IMPORTANT: The cast iron pan supports on the appliance are much heavier than those on most gas hotplate cookers, therefore care must be taken when removing or re-fitting them to the hob.

It is important that they are lifted from the appliance and not dragged across nearby enamelled parts which would result in damaging the enamel.

Fitting of burner cap (*rapid and semi-rapid*)

Place burner cap over retaining lugs, then turn cap clockwise to lock into position (Fig. 14.1) and (Fig. 14.2).

Assembly of wok burner (Fig. 14.3)

Fig. 14.2

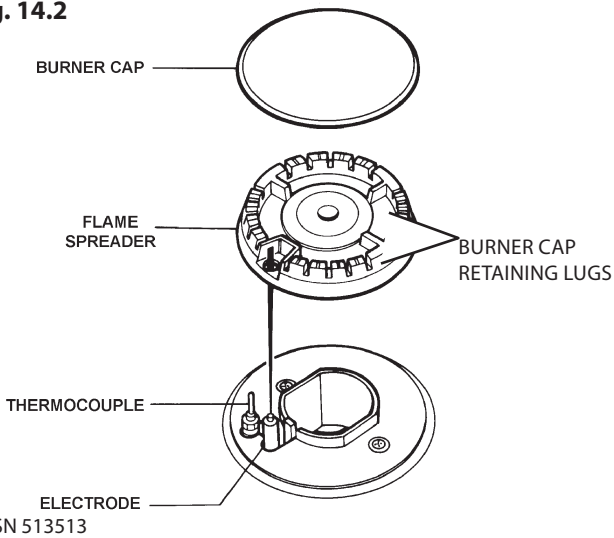
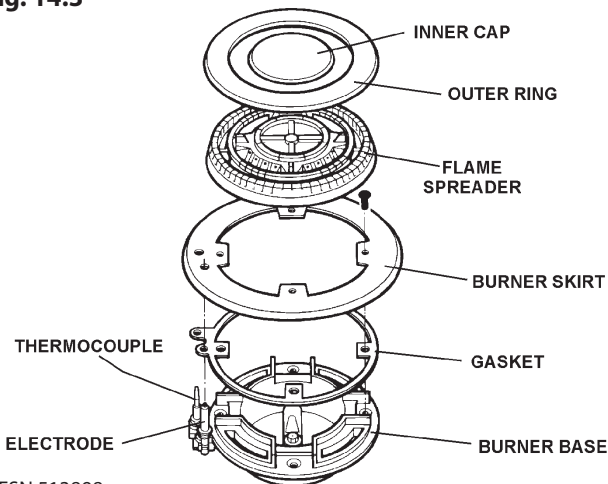

Fig. 14.3



Gas connection

⚠ CAUTION: ENSURE THAT THE APPLIANCE IS ISOLATED FROM ELECTRIC SUPPLY

The appliance can be installed with an approved flexible connection. Supply piping should not be less than $\frac{3}{8}$ I/D. Connection is made to the $R\frac{1}{2}$ ($\frac{1}{2}$ " BSP) female threaded fitting located just below the hotplate level on the rear right-hand side of the appliance.

The gas bayonet connector provided, must be fitted to the wall in the shaded area dimensioned in **Fig. 14.6**. Take into account that it must be possible to pull the appliance forward sufficiently for servicing. Ensure flexible hose is not trapped between appliance back panel and rear wall. Ensure hose is routed away from the vent slots in the back panel. The flexible hose must be in accordance with the relevant standards.

⚠ IMPORTANT: The gas supply connection at the wall must not project out from the wall by more than 45mm, so that it does not foul with the back of the appliance Fig. 14.6.

FLEXIBLE HOSE

The flexible hose must be suitable with the type of gas being used. LPG hoses carry a red stripe, band or label. If in doubt ask your supplier.

For an appliance other than an upright appliance, which may be connected with a hose assembly. The supply connection point must be accessible with the appliance installed.

NOTE: Use soapy water solution on new gas connections to ensure there are no gas leaks.

Check for gas tightness after connecting the appliance.

Pressure testing

NOTE: The regulator is set for N.G. or for Propane X put out of action.

The pressure test point is situated just below the hotplate level on the rear right-hand side of the appliance (**Fig. 14.5**).

- For Natural Gas manifold pressure is 1kPa (4" w.g.)
- For L.P.G. (Propane X Only) manifold pressure 2.54kPa (10" w.g.).
- Re-fit test point blanking screw and check for gas tightness.

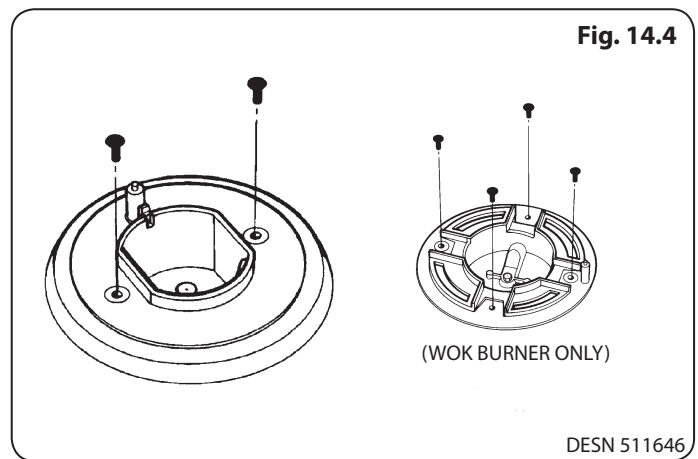

DESN 511646

POSITION OF GAS BAYONET ON WALL **Fig. 14.6**
(locate in shaded areas)

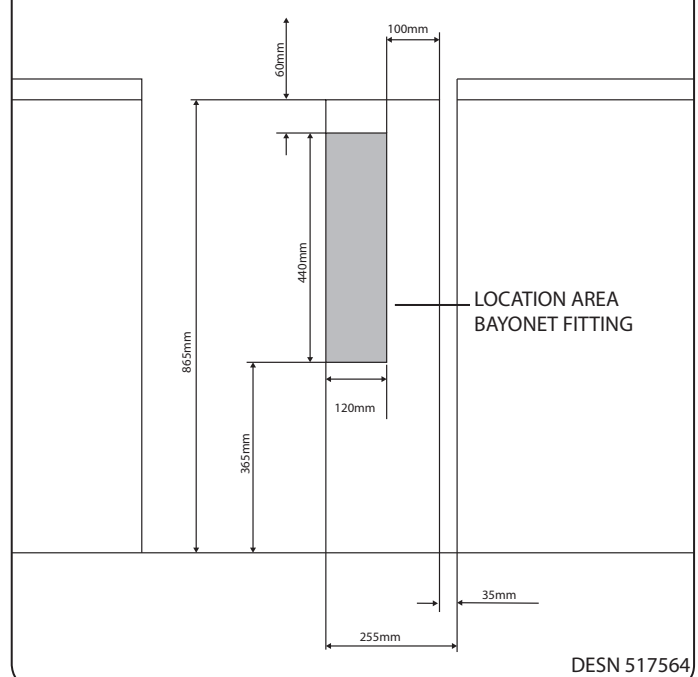

DESN 517564

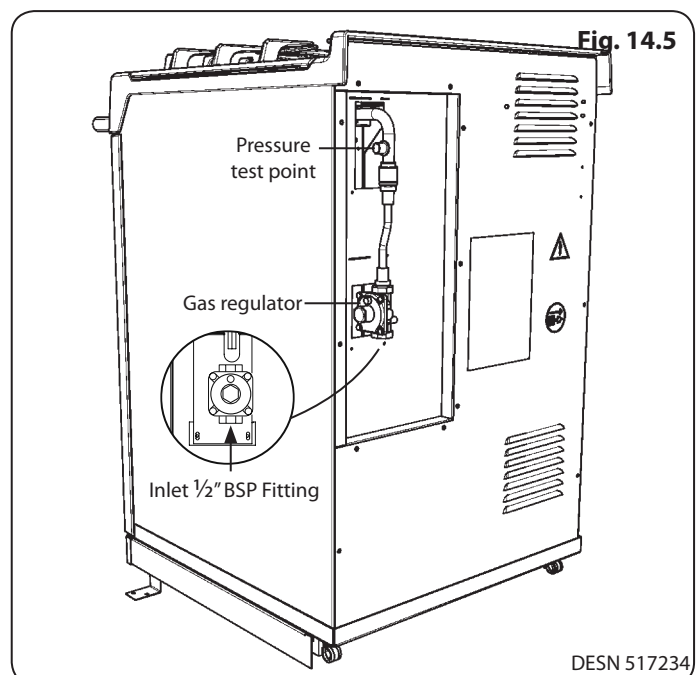

DESN 517234

Fig. 14.7

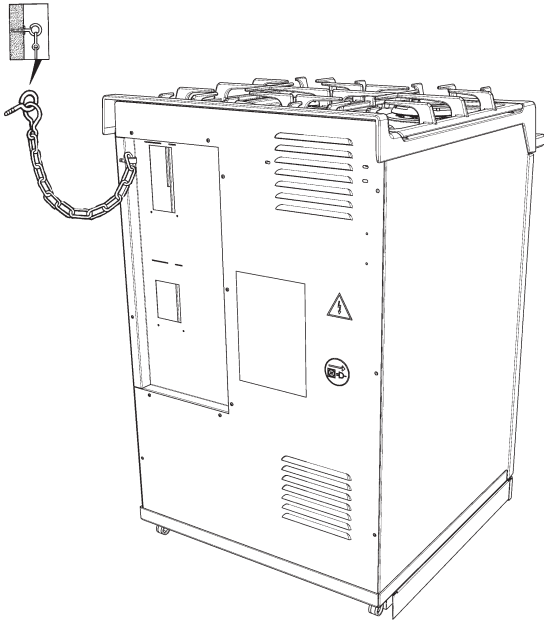

DESN 517192

Cooker stability

A safety chain must be anchored firmly to the wall and cooker to prevent the flexible hose from straining, when the cooker is withdrawn for servicing. When fitting a safety chain refer to **Fig. 14.7**.

Restraint where a hose assembly is used, shall have means to limit the extent of movement of the gas appliance to no greater than 80% of the hose assembly length.

If disconnection of the restraining chain is necessary, then ensure restraining chain is re-attached as appliance is relocated in its original position to avoid serious injury or fatality.

Reassemble the burner caps (**Fig. 14.2**) and (**Fig. 14.3**), wok burner (**Fig. 14.4**) and re-fit the pan support

To adjust pan support level

1. Loosen retaining nut using 8mm spanner (**Fig. 14.8**).
2. To prevent rocking adjust the pan support foot using 2.5mm allen key.
3. Check pan support is level with opposing pan supports.
4. Retighten retaining nut.

Fig. 14.8

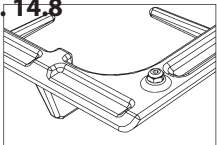

DESN 517187

Control knob and bezel location

1. Ensure control knobs and bezels are located onto spindles correctly, as shown in (**Fig. 14.9**).

Handrail location

1. Locate handrail onto spindle, lock into position with grub screws (located on the underside of the bracket) (**Fig. 14.9**).

Fig. 14.9

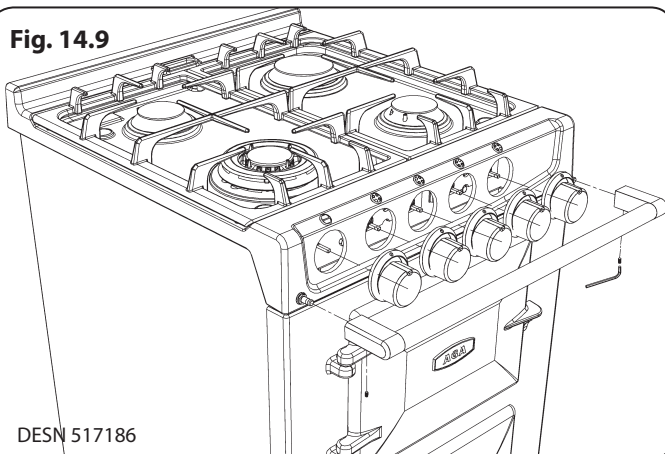

DESN 517186

15. Circuit diagram

CAUTION: label all wires prior to disconnection when servicing controls wiring errors can cause improper and dangerous operation. Verify proper operation after servicing.

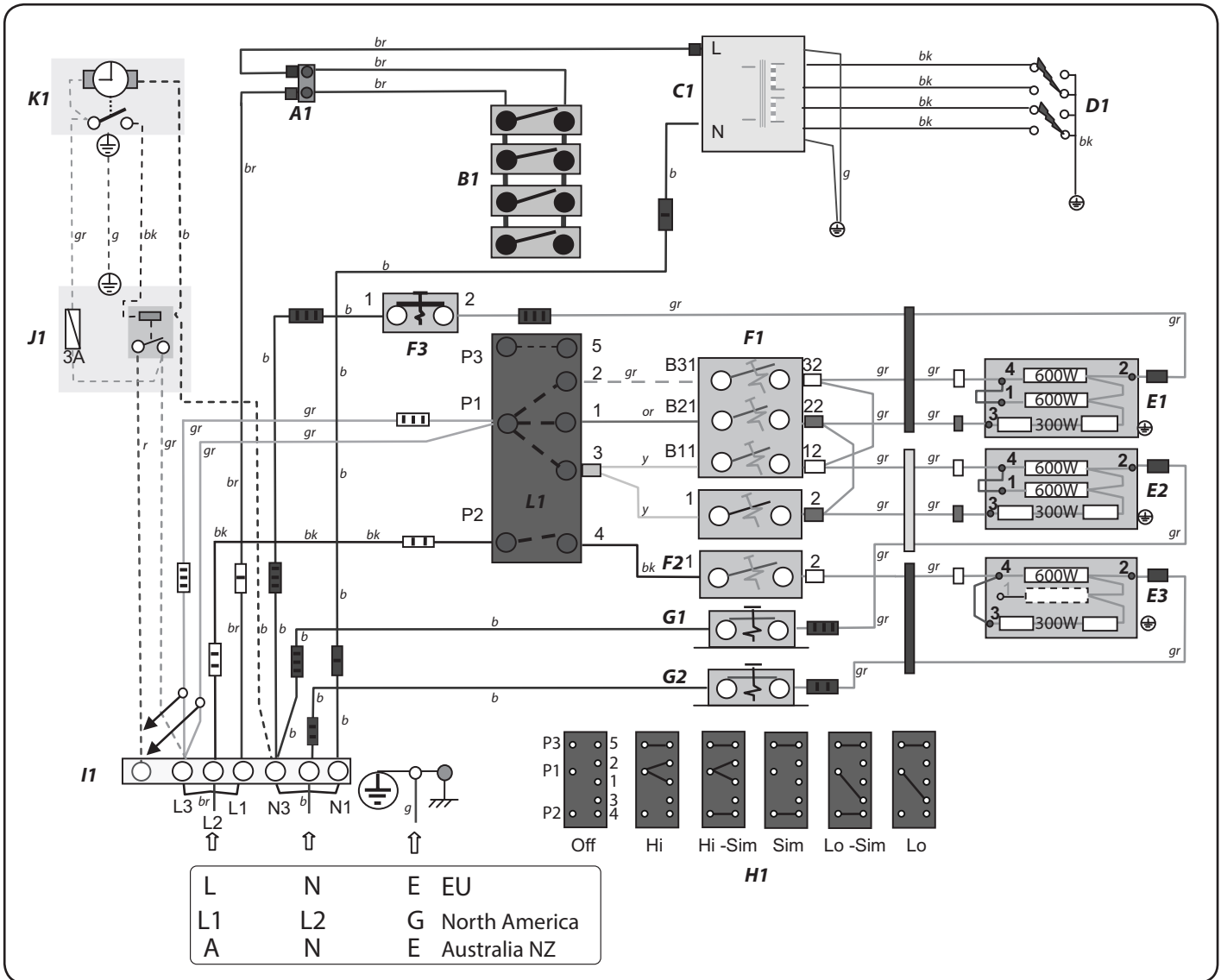

Code	Description
A1	Terminal block
B1	Tap ignition switch
C1	Spark generator
D1	Electrode
E1	Upper oven top element
E2	Upper oven base element
E3	Lower oven base element
F1	Upper oven thermostat
F2	Lower oven thermostat
F3	Upper ovenheat thermostat

Code	Description
G1	Upper oven overheating switch
G2	Lower oven overheating switch
H1	Selector setting
I1	Mount terminal bracket
J1	Relay box
K1	Upper oven timer
L1	Selector

Code	Colour
b	Blue
br	Brown
bk	Black
or	Orange
r	Red
v	Violet
w	White
y	Yellow
g/y	Green/yellow
gy	Grey

NOTE:

1. Ignition switches and thermostats are shown in the off position with the appliance cold and fan oven door is closed.
2. The appliance is cold (ie. Cut-in & cut-out not operated)

16. Technical data

This appliance is supplied set for Natural Gas (NG) at a pressure of 1 kPa (4" wg). It must be converted to run on Propane X, at a pressure of 2.54 kPa (10" wg).

HOTPLATE - Natural Gas	Left-hand Front	Right-hand Rear	Left-hand Rear	Right-hand Front
BURNER TYPE	ULTRA-RAPID WOK	RAPID	SEMI-RAPID	SEMI-RAPID
MAXIMUM HEAT INPUT	3.9 KW	3.5 KW	1.95 KW	1.95 KW
	14.0 MJ/h	12.5 MJ/h	7.0 MJ/h	7.0 MJ/h
INJECTOR MARKING	170	155	118	118

PRESSURE POINT POSITION:	Just below hotplate level on rear right-hand side of the appliance.
PRESSURE SETTING:	1 kPa (4" wg)
BURNER IGNITION:	H.T. Spark

HOTPLATE - Propane X	Left-hand Front	Right-hand Rear	Left-hand Rear	Right-hand Front
BURNER TYPE	ULTRA-RAPID WOK	RAPID	SEMI-RAPID	SEMI-RAPID
MAXIMUM HEAT INPUT	12.5 MJ/h	11.5 MJ/h	6.8 MJ/h	6.8 MJ/h
	3.5 KW	3.2 KW	1.9 KW	1.9 KW
	(247 g/h) (0.49l/h)	(227 g/h) (0.45l/h)	(134 g/h) (0.28 l/h)	(134 g/h) (0.28 l/h)
INJECTOR SIZE (mm)	1.05	0.94	0.72	0.72

PRESSURE POINT POSITION:	Just below hotplate level on rear right-hand side of the appliance.
PRESSURE SETTING:	2.54 kPa (10" wg)
BURNER IGNITION:	H.T. Spark
ELECTRIC GRILL AND OVENS:	240 VOLT, 50 Hz, SINGLE PHASE 30 AMP
TOP OVEN POWER RATING	3.0 kw (230V) / 3.2 kw (240V)
LOWER OVEN	0.9 kw (230V) / 1.0 kw (240V)

The data plate is located on a pull out plate, behind the plinth cover.

Weight of appliance: 215 kg (474 lbs)

Gas hob overview Fig. 16.1

- A. Oven knob
- B. Wok burner and knob
- C. Rear semi-rapid burner and knob
- D. Rear rapid burner and knob
- E. Front semi-rapid burner and knob

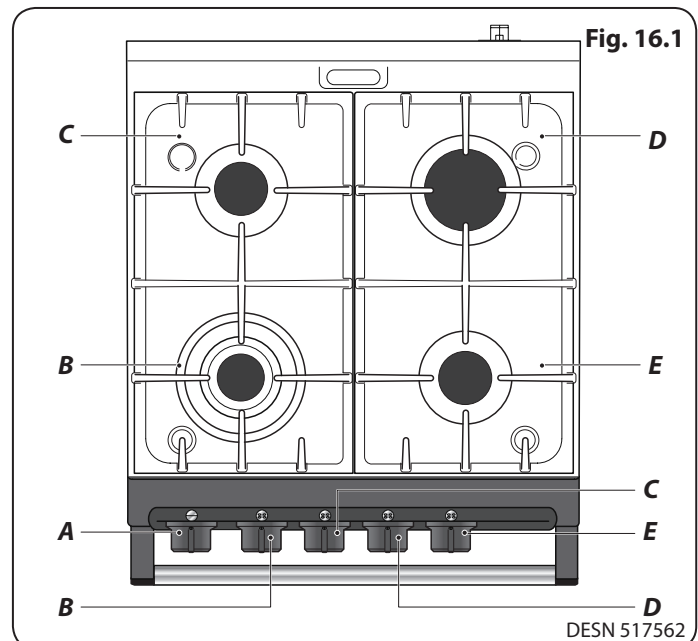

17. Checklist

Hand these instructions to the user for retention, and instruct in the safe operation of the appliance.		
Serial No.		Tick Box / Not Applicable (N/A)
Check pan supports, gas hotplate burners are correctly fitted.		
Check gas pressure is correct.		
Check fit of control knobs and bezels.		
Check hotplate burner ignition.		
Check hotplate lids and settings.		
Check oven door seals, adjust door alignment if necessary.		
Baking and Simmering oven rope seals MUST have a gap between the door hinges. The Roasting Oven is fitted with a continuous seal.		
Ensure any plastic film is removed from the inside of the oven doors.		
Turn on roasting and simmering oven.		
Guide customer through the Users Instructions of the appliance, offering best practices on oven maintenance, energy usage, enamel cleaning (boiled vegetable water staining on enamel etc.)		
Engineer's Signature Date		

Notes

Notes

Notes

Notes

**For further advice or information contact
your local AGA Specialist.**

With AGA Rangemaster's policy of continuous product improvement, the Company reserves the right to change specifications and make modifications to the appliances described and illustrated at any time.



Manufactured By
AGA Rangemaster
Station Road
Ketley Telford
Shropshire TF1 5AQ
England

www.agaliving.com
www.agacookshop.co.uk