



LPRT 517777

AGA eR7 and R7 Hotcupboard with Induction Hob

THESE INSTRUCTIONS MUST BE READ IN CONJUNCTION WITH THE
MAIN COOKER INSTALLATION AND USERS GUIDE



Owners Manual Users and Installation Guide

REMEMBER: when replacing a part on this appliance, use only spare parts that you can be assured conform to the safety and performance specification that we require. **DO NOT** use reconditioned or copy parts that have not been clearly authorised by AGA.

PLEASE KEEP THESE INSTRUCTIONS IN A SAFE PLACE FOR FUTURE REFERENCE

CE For use in GB and IE

09/19 EINS 517778

Contents

Users Guide	2
Introduction	2
Safety	2
Pans	3
Induction Hob	3
Switching the Induction Hob ON	3
Setting the Power Level	3
Switching the Induction Hob OFF	3
Pan Detection	4
Residual Heat Indicator	4
Pause	4
Warming Function	4
Auto Cook	4
Minute Timer	5
Control Locking	5
Overheat Protection	5
Example of Induction Hob Use	6
Hotcupboard	6
Cleaning	7
Installation Guide	8
Electrical Connection	8
Warranty and Service	8
Wiring Diagram	9

Users Guide

Introduction

Thank you for choosing the AGA eR7/R7 Hotcupboard with Induction Hob. The induction hob is an efficient way of cooking and will give you more control during the cooking process. The hotcupboard provides gentle heat, in the form of a slow cooking oven and warming oven.

Please read these instructions to ensure a full understanding of the controls and the precautions required prior to their use.

Safety

Please read the following points carefully.

- **Important information for pacemakers and insulin pump users.** The functions of this induction hob complies with applicable standards for electromagnetic interference. If you are fitted with such a device and have concerns please consult your doctor for medical advice.
- This appliance is not intended for use by persons (including children under 8) with reduced physical, sensory and mental capabilities, or lack of experience and knowledge, unless they have had or been given supervision or instruction concerning its use by a person responsible for their safety and understand the hazards involved.
- Children shall not play with the appliance. Cleaning and user maintenance shall not be made by children without supervision.
- Do not use a cracked or broken hob. Should a crack appear and to avoid electric shock, disconnect the appliance from the electrical supply and arrange for its repair.
- Surfaces on and around the appliance may get hotter than expected and remain hot during and for a while after use, children should be kept away during this time.
- When the hob is in use keep items that use a magnetic storage medium, such as credit cards away.
- Metallic objects such as cutlery, should not be placed or stored on the induction hob as they may get hot. Cutlery, utensils and unused pans should be stored elsewhere.
- **DO NOT** allow saucepan handles to overhang the hob.
- **DO NOT** slide cooking pans over the hob.
- After use, turn the induction hob off, **DO NOT** rely on the pan sensor.
- **DO NOT** use the hob as a cutting board.
- **DO NOT** use the appliance to dry clothes and other combustible materials.
- **DO NOT** obstruct appliance vents by placing towels, clothes etc. on the hand rail.
- **DO NOT** use steam cleaners on your appliance.
- To avoid overheating, the appliance must not be installed behind a decorative door.

Fire!

- To avoid fire. **NEVER** leave a chip pan or a pan containing oil unattended. Always heat oil slowly and watch as it heats. To prevent spillage do not fill a pan more than a third of its capacity, this will prevent spill over when adding food.
- **DO NOT** use water on a fat/oil fire. **NEVER** move the pan. Turn off the appliance at the wall switch and carefully smother the flame with a lid, fire blanket or use an approved dry extinguisher.

Pans

It is important to use pans that are specifically recommended for induction cooking. Generally stainless steel, special pans with stainless steel bases, enamelled steel, or cast iron pans with flat enamelled bases are suitable. It should be noted that some grades of stainless steel pans may not function or may be slow to heat.

All copper and all aluminium constructed pans or ceramic pans, will not work on an induction hob. If you are unsure of a pan, try a quick test using a magnet on the pan base (See **Fig. 2**). A strong attraction between magnet and pan, will normally indicate a suitable pan. Weak or no attraction usually indicates a pan that is not suitable. Do not forget to remove the magnet before using the pan on the hob.

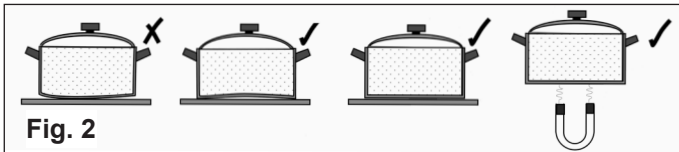

Fig. 2

Use pans that are the same size or slightly larger than the marked area. Smaller pans will take longer to heat. Using a pan with a lid will help pan contents boil more quickly.



Fig. 3

Ideally pans should have near flat bottoms to maximise induction efficiency.

Most types of pans will generate a faint audible sound during the cooking process and this is perfectly normal. The level of sound will vary depending on the type and style of pan used.

AGA accessories can be viewed at your local AGA specialist or online at agacookshop.co.uk.

Induction Hob

The induction hob works independent of the AGA hotcupboard. It is not necessary for the hotcupboard control switch to be on when the induction hob is in use.

All of the induction hob functions are accessed via the touch pads located on the ceramic surface.

Display Indicators

A	Auto Cook		Warming settings
U	Pan detection		Timer set
H	Residual heat		Pause set
-L-	Lock set		Power levels
P	Boost		Prolonged pad contact

Control Panel Fig. 4

Always use positive finger contact on the touch pads to ensure a good control response.

Touch pads may not respond if the hob control area is wet. Touch pad area should be dried using paper towel.

Switching the Induction Hob ON

Using the induction hob requires three steps.

1. Touch the power on - off pad
2. Touch the induction on - off pad
3. Set the required power level

If power level is not set within 20 seconds the unit will automatically switch off.

Setting the Power Level

Ten power levels can be selected by touching an individual power level pad or by sliding your finger along the pads. A visual indicator will illuminate as both a numerical and as a level display , being high.

To set the boost function, touch boost pad the display will indicate . The boost function will run for 10 minutes maximum before reverting back to setting .

Switching the Induction Hob OFF

After use the hob should be turned off by touching the power touch pad .

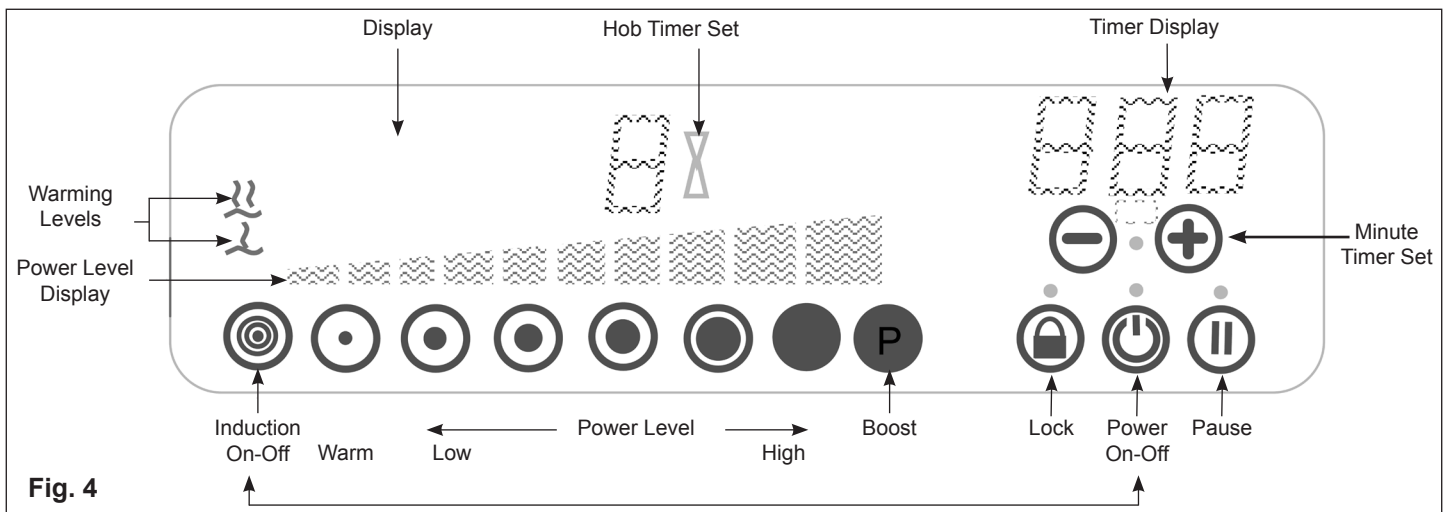

Fig. 4

Pan Detection

When the power is on and a power level is selected, the pan detection will be automatic whenever the pan is placed within or removed from the cooking zone on the hob. (See Fig. 3 for defined pan area and Fig. 5 for pan location).



Fig. 5

If there is no pan placed on the cooking surface the display will flash .

Always switch off by touching the power pad when the hob is not in use.

Residual Heat Indicator

The hob surface will get hot when in use, this is due to heat being conducted from the cooking pan. The hob surface will also remain hot for a while after use.

After the cooking period the hob hot indicator will be displayed and for a short period of time after power off.

Pause

To interrupt the cooking period, touch the pause touch pad , cooking will stop and will be displayed.

To recommence cooking, touch pause pad and then slide your finger the full length of the power level pads, through to the original power level will be automatically set.

Pause remains active for 10 minutes only, after 10 minutes the hob will switch off.

Warming Function

The warming function will keep cooked food warm for a set period of time.

Touch the power on - off pad . Touch the induction on - off pad and touch the first power level pad to select warming level one, the warming indicator and will be displayed.

To select the second and higher warming level, touch and hold the first power level pad . The warming indicator and will be displayed. The warming temperatures are as indicated below.

Level	Temperature
1	40°C 104°F
2	70°C 158°F

Auto Cook

The Auto Cook feature allows the pan contents to be brought up to a high temperature rapidly, before reverting back to the set power level.

To set Auto Cook

1. Touch power on pad and then touch induction on pad .
2. Touch required power level pad for 5 seconds. The symbol along with the set level, will flash in the display.
3. Turn off the hob by touching the off pad after cooking is complete.

Minute Timer





The hob has two individual timers:



Kitchen Timer, for general kitchen timing requirements, for example, timing food cooked in an oven.

Minute Minder, for timing the duration of the induction cooking process.

The timer functions do not start or stop a cooking process.

Kitchen Timer



Touch power pad  and then   pads together,   will be displayed.

A time can now be set using  or  touch pads. The count down will commence after a few seconds. If an instant countdown is required touch the power pad .



After the set time has elapsed the audible alarm can be cancelled by touching the power off pad .





To modify or cancel a previously set time, touch

power pad  (on) and then   pads together.





Release and then touch either the  or  pad to adjust the time setting, or set to zero time.

Minute Minder

Touch power pad  followed by induction on pad , set the required power level .

Touch pads   together  will be displayed, use  and  pads to set time. The count down will commence after a few seconds.

After set time has elapsed the audible alarm can be cancelled by touching the power off pad .

To modify a previously set time, touch   pads together and adjust using  and  pads.

The timer with the shortest time period remaining will show in the display.

Control Locking

There are two control locking features:

1. **Temporary Lock**, this feature will lock the controls for the duration of a cooking process to prevent accidental adjustment of the controls.
2. **Fixed Lock**, will lock the controls, even when the hob is powered off, this feature is to prevent accidental and unsupervised hob use and will require manual intervention before use, or deactivation of the feature.

Power off pads  and  will always function.



Temporary Control Lock

Touch power button  followed by induction on pad .

Set to required power level . Touch lock key .



Power levels only, are locked to prevent adjustment during a cooking period.



To unlock, touch the lock pad  to enable power level adjustment, or power pad  to turn the hob off.



To remove the feature, after use touch power on pad  and then lock pad .

Fixed Control Lock

Touch pads can be locked to prevent unsupervised control function, even after the hob has been powered off. Manual intervention or a deactivation sequence will be required to return the hob to normal operation.



To activate the fixed lock. Touch power pad , followed by induction on pad .

Touch lock and pause pads together , release and then touch lock pad .  will be displayed.

Manual intervention will be required to release the control functions for use. This is done by touching lock and pause pads together  followed by induction on  pad.

The hob control function will now be normal.

When the hob is switched off the Fixed Lock will still be active.

To deactivate the Fixed Lock. Touch power pad , touch lock and pause pads together , release and then immediately touch the pause  pad.

If deactivation fails wait 20 seconds before retrying or turn the appliance off at wall switch.

Overheat Protection

Power levels will be automatically reduced if excessive high temperatures are monitored below the cooking zone. If high temperatures are detected it will not be possible to adjust the power level to a higher level than shown in the visual displays.

Should a pan be allowed to boil dry the overheat system will turn the hob off.

Example of Induction Hob Use

Place an appropriate pan containing food to be heated, onto the induction hob.

Touch the power on pad , touch the induction on pad .

Set power level by sliding your finger along the power level pads to the required setting.

To simmer, slide your finger down the power level pads for a lower setting.

Turn the hob off after pan contents are heated, by touching the power off pad .

Remove the pan from the hob carefully, as it will be hot.

Hotcupboard

Slow Cooking Oven plus Warming Oven

These ovens are heated by a single element at the rear of the oven cavity. It is operated by a single push ON-OFF button located on the left hand side of the hotcupboard top plate and can be turned ON and OFF when required. (See **Fig. 6**). These ovens are not cast iron on the interior.

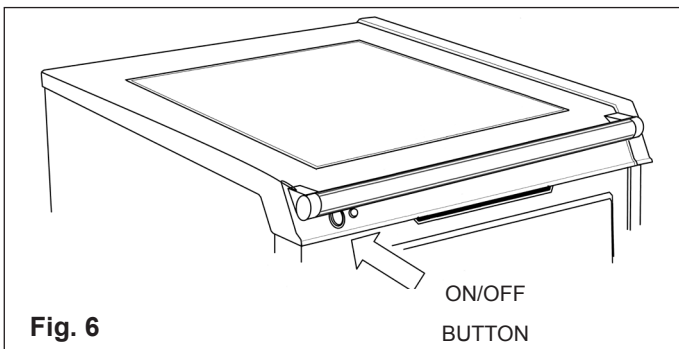

Slow Cooking Oven

This oven has similar characteristics to a simmering Oven and should be utilised in a similar manner. It delivers a gentler convected heat making it better suited for longer cooking times especially for overnight cooking, for example, rich fruit cakes and celebration cakes. The cooking of meringues may also be better suited in the hotcupboard

NOTE: These ovens vent into the room, mechanical venting to the outside is not available.

Points to remember when Slow Cooking:

- Pre-heat the oven for 30 minutes before starting to cook.
- Bring casseroles, soups etc to the boil on the hotplate and start meats in the roasting oven for 30 minutes.
- Make sure that casseroles have sufficient liquid, particularly when cooking over a long period.
- Use lids on casseroles or foil to cover food whilst it is cooking to retain moisture.
- Make sure all dishes will fit into the oven before preparing food.
- Make sure that meat and poultry is piping hot before eating and reaches 75°C internal temperature.
- Always thaw frozen food completely before cooking.

You can also produce crisp white meringues in the slow cooking oven.

Timings for slow cooking oven will depend upon the temperature, quantity and type of dish you are cooking, as a guide for casseroles, a minimum of 2 hours cooking time is recommended.

Keep an eye on the food until you are familiar with the oven.

Cleaning

Make sure all the surfaces have cooled prior to cleaning the hob and front plate.

The easiest way to clean the AGA Induction Hob and front plate is to mop up spills as soon as they happen. It may be useful to keep a damp cloth handy to do this. The ceramic surface should then be cleaned with a proprietary cleaner such as Hob Brite or Easy Do.

DO NOT USE HOB BRITE ON ENAMELLED SURFACES.

If milk or fruit juice or anything containing acid, is spilt on the cooker, wipe it up immediately.

Also, clean off any condensation streaks on the front plate around the oven doors or the vitreous enamel maybe permanently discoloured.

All that is usually needed to keep the vitreous enamel surfaces of the cooker bright and clean is a daily rub over with a damp soapy cloth followed immediately with a clean, dry cloth to avoid streaks. The AGA E-cloths are excellent for this.

Ensure the lower vent is cleaned on a regular basis, and free from obstruction, to maintain sufficient air flow through the appliance. (The louvered plinth fascia can be easily removed for cleaning).

Oven Door Linings

The best way to keep the linings clean is to wipe them over after cooking (be careful with a hot cooker), so that splashes do not get baked on.

Clean the linings when they are cool and the cooker is off. The linings can be cleaned with hot soapy water

and /or a cream cleanser. To deep clean the linings, place a towel on the work surface and carefully lift off the oven door (doors are heavy). Place it enamel side down on the towel padding. Clean with a soapy impregnated pad to remove stubborn marks. Do not immerse the doors in water as they are packed with insulating material which will be damaged by excessive moisture. Dry off before carefully replacing on their hinges.

DO NOT put oven doors in a dishwasher.

Installation Guide

Please refer to the main cooker installation guide for product dimensions following the Hotcupboard instructions.

Electrical Connection

THE HOTCUPBOARD ATTACHMENT REQUIRES AN INDEPENDENT SINGLE PHASE POWER SUPPLY.

IF THE SUPPLY CORD IS DAMAGED, IT MUST BE REPLACED BY THE MANUFACTURER, ITS SERVICE AGENT OR SIMILARLY QUALIFIED PERSONS IN ORDER TO AVOID HAZARD.

WARNING: THIS APPLIANCE MUST BE EARTHED

The induction hob with hotcupboard requires an independent single phase power supply and for the voltage stated on the rating plate, **230v ~ 50 Hz, 13 amp fused electrical supply.**

The appliance is designed for the voltage stated on the rating plate, which is situated on a slide-out tray in the hotcupboard base plate above the plinth.

External wiring to the unit must be installed using the supplied 3 core heat resisting PVC insulated cable and in accordance with the current wiring regulations and any local regulations which apply.

The method of connection to the mains electricity supply must facilitate complete electrical isolation of the appliance, preferably by a fused double pole switch, having a contact separation of at least 3mm in both poles.

The isolator must not be positioned immediately above the appliance, but must be fitted within 2 metres of the appliance.

Warranty and Service

Please refer to main guide for warranty and service detail.

Wiring Diagram

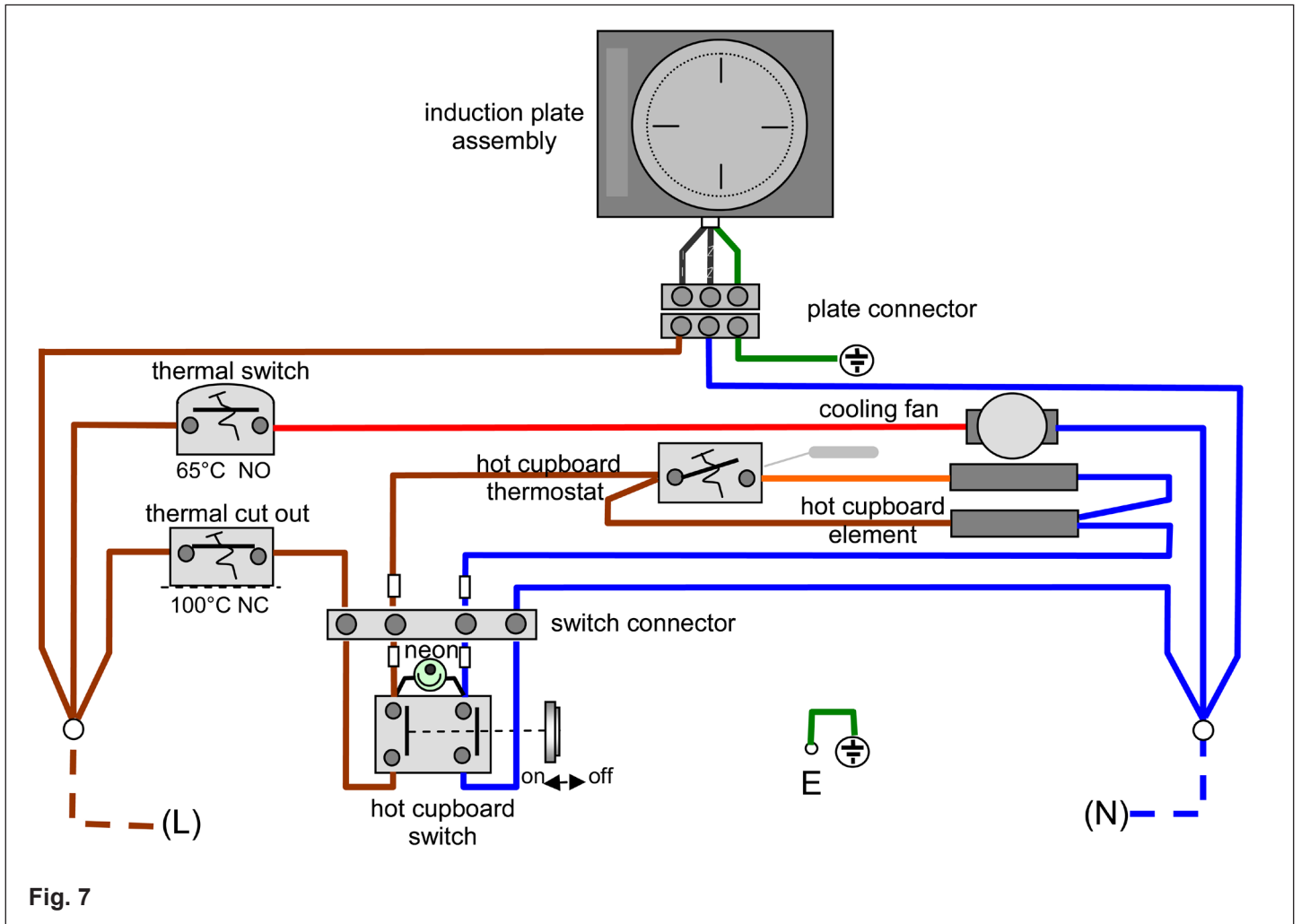

**For further advice or information contact
your local AGA Specialist**

With AGA Rangemaster's policy of continuous product improvement, the Company reserves the right to change specifications and make modifications to the appliance described and illustrated at any time.



Manufactured by
AGA Rangemaster
Station Road
Ketley Telford
Shropshire TF1 5AQ
England

www.agaliving.com
www.agacookshop.co.uk